

CE:CIVIL ENGINEERING

Duration: Three Hours

Maximum Marks:100

Please read the following instructions carefully:

General Instructions:

1. Total duration of examination is 180 minutes (3 hours).
2. The clock will be set at the server. The countdown timer in the top right corner of screen will display the remaining time available for you to complete the examination. When the timer reaches zero, the examination will end by itself. You will not be required to end or submit your examination.
3. The Question Palette displayed on the right side of screen will show the status of each question using one of the following symbols:



You have not visited the question yet.



You have not answered the question.



You have answered the question.



You have NOT answered the question, but have marked the question for review.



You have answered the question, but marked it for review.

The Marked for Review status for a question simply indicates that you would like to look at that question again. ***If a question is answered and Marked for Review, your answer for that question will be considered in the evaluation.***

Navigating to a Question

4. To answer a question, do the following:
 - a. Click on the question number in the Question Palette to go to that question directly.
 - b. Select an answer for a multiple choice type question. Use the virtual numeric keypad to enter a number as answer for a numerical type question.
 - c. Click on **Save and Next** to save your answer for the current question and then go to the next question.
 - d. Click on **Mark for Review and Next** to save your answer for the current question, mark it for review, and then go to the next question.
 - e. **Caution: Note that your answer for the current question will not be saved, if you navigate to another question directly by clicking on its question number.**
5. You can view all the questions by clicking on the **Question Paper** button. Note that the options for multiple choice type questions will not be shown.

Answering a Question

6. Procedure for answering a multiple choice type question:
 - a. To select your answer, click on the button of one of the options
 - b. To deselect your chosen answer, click on the button of the chosen option again or click on the **Clear Response** button
 - c. To change your chosen answer, click on the button of another option
 - d. To save your answer, you **MUST** click on the **Save and Next** button
 - e. To mark the question for review, click on the **Mark for Review and Next** button. *If an answer is selected for a question that is Marked for Review, that answer will be considered in the evaluation.*

7. Procedure for answering a numerical answer type question:
 - a. To enter a number as your answer, use the virtual numerical keypad
 - b. A fraction (eg., -0.3 or -.3) can be entered as an answer with or without '0' before the decimal point
 - c. To clear your answer, click on the **Clear Response** button
 - d. To save your answer, you **MUST** click on the **Save and Next** button
 - e. To mark the question for review, click on the **Mark for Review and Next** button. *If an answer is entered for a question that is Marked for Review, that answer will be considered in the evaluation.*

8. To change your answer to a question that has already been answered, first select that question for answering and then follow the procedure for answering that type of question.

9. Note that **ONLY** Questions for which answers are saved or marked for review after answering will be considered for evaluation.

Paper specific instructions:

1. There are a total of 65 questions carrying 100 marks. Questions are of multiple choice type or numerical answer type. A multiple choice type question will have four choices for the answer with only **one** correct choice. For numerical answer type questions, the answer is a number and no choices will be given. **A number as the answer should be entered** using the virtual keyboard on the monitor.
2. Questions Q.1 – Q.25 carry 1mark each. Questions Q.26 – Q.55 carry 2marks each. The 2marks questions include two pairs of common data questions and two pairs of linked answer questions. The answer to the second question of the linked answer questions depends on the answer to the first question of the pair. If the first question in the linked pair is wrongly answered or is not attempted, then the answer to the second question in the pair will not be evaluated.
3. Questions Q.56 – Q.65 belong to General Aptitude (GA) section and carry a total of 15 marks. Questions Q.56 – Q.60 carry 1mark each, and questions Q.61 – Q.65 carry 2marks each.
4. Questions not attempted will result in zero mark. Wrong answers for multiple choice type questions will result in **NEGATIVE** marks. For all 1 mark questions, $\frac{1}{3}$ mark will be deducted for each wrong answer. For all 2 marks questions, $\frac{2}{3}$ mark will be deducted for each wrong answer. However, in the case of the linked answer question pair, there will be negative marks only for wrong answer to the first question and no negative marks for wrong answer to the second question. There is no negative marking for questions of numerical answer type.
5. Calculator is allowed. Charts, graph sheets or tables are **NOT** allowed in the examination hall.
6. Do the rough work in the Scribble Pad provided.

Q. 1 – Q. 25 carries one mark each.

- Q.1 There is no value of x that can simultaneously satisfy both the given equations. Therefore, find the 'least squares error' solution to the two equations, i.e., find the value of x that minimizes the sum of squares of the errors in the two equations. _____

$$2x = 3$$

$$4x = 1$$

- Q.2 What is the minimum number of multiplications involved in computing the matrix product PQR ? Matrix P has 4 rows and 2 columns, matrix Q has 2 rows and 4 columns, and matrix R has 4 rows and 1 column. _____

- Q.3 A 1-h rainfall of 10 cm magnitude at a station has a return period of 50 years. The probability that a 1-h rainfall of magnitude 10 cm or more will occur in each of two successive years is:

(A) 0.04 (B) 0.2 (C) 0.02 (D) 0.0004

- Q.4 Maximum possible value of Compacting Factor for fresh (green) concrete is:

(A) 0.5 (B) 1.0 (C) 1.5 (D) 2.0

- Q.5 As per IS 800:2007, the cross-section in which the extreme fiber can reach the yield stress, but cannot develop the plastic moment of resistance due to failure by local buckling is classified as

(A) plastic section (B) compact section
(C) semi-compact section (D) slender section

- Q.6 The creep strains are

(A) caused due to dead loads only
(B) caused due to live loads only
(C) caused due to cyclic loads only
(D) independent of loads

- Q.7 As per IS 456:2000 for M20 grade concrete and plain bars in tension the design bond stress $\tau_{bd} = 1.2 \text{ MPa}$. Further, IS 456:2000 permits this design bond stress value to be increased by 60 % for HSD bars. The stress in the HSD reinforcing steel bars in tension, $\sigma_s = 360 \text{ MPa}$. Find the required development length, L_d , for HSD bars in terms of the bar diameter, ϕ . _____

- Q.8 The 'plane section remains plane' assumption in bending theory implies:

(A) strain profile is linear
(B) stress profile is linear
(C) both strain and stress profiles are linear
(D) shear deformations are neglected

- Q.9 Two steel columns P (length L and yield strength $f_y = 250 \text{ MPa}$) and Q (length $2L$ and yield strength $f_y = 500 \text{ MPa}$) have the same cross-sections and end-conditions. The ratio of buckling load of column P to that of column Q is:
- (A) 0.5 (B) 1.0 (C) 2.0 (D) 4.0
- Q.10 The pin-jointed 2-D truss is loaded with a horizontal force of 15 kN at joint S and another 15 kN vertical force at joint U, as shown. Find the force in member RS (in kN) and report your answer taking tension as positive and compression as negative. _____

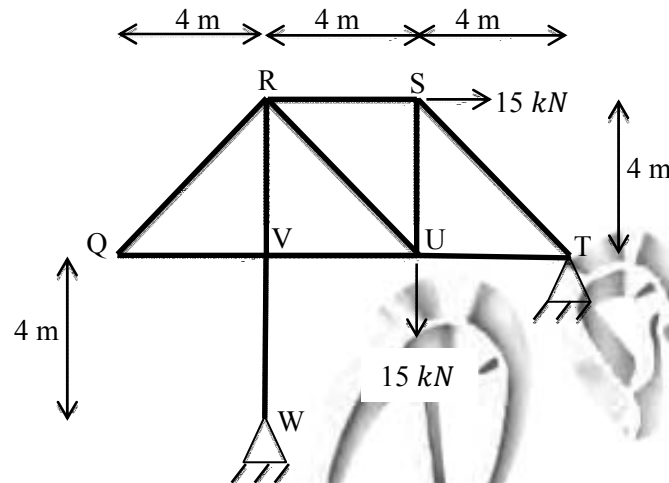

- Q.11 A symmetric I-section (with width of each flange = 50 mm , thickness of each flange = 10 mm , depth of web = 100 mm , and thickness of web = 10 mm) of steel is subjected to a shear force of 100 kN . Find the magnitude of the shear stress (in N/mm^2) in the web at its junction with the top flange. _____
- Q.12 In its natural condition, a soil sample has a mass of 1.980 kg and a volume of 0.001 m^3 . After being completely dried in an oven, the mass of the sample is 1.800 kg . Specific gravity G_s is 2.7. Unit weight of water is 10 kN/m^3 . The degree of saturation of the soil is:
- (A) 0.65 (B) 0.70 (C) 0.54 (D) 0.61
- Q.13 The ratio N_f/N_d is known as shape factor, where N_f is the number of flow lines and N_d is the number of equipotential drops. Flow net is always drawn with a constant b/a ratio, where b and a are distances between two consecutive flow lines and equipotential lines, respectively. Assuming that b/a ratio remains the same, the shape factor of a flow net will change if the
- (A) upstream and downstream heads are interchanged
 (B) soil in the flow space is changed
 (C) dimensions of the flow space are changed
 (D) head difference causing the flow is changed

- Q.14 Following statements are made on compacted soils, wherein DS stands for the soils compacted on dry side of optimum moisture content and WS stands for the soils compacted on wet side of optimum moisture content. Identify the *incorrect* statement.
- (A) Soil structure is flocculated on DS and dispersed on WS.
 (B) Construction pore water pressure is low on DS and high on WS.
 (C) On drying, shrinkage is high on DS and low on WS.
 (D) On access to water, swelling is high on DS and low on WS.
- Q.15 Four columns of a building are to be located within a plot size of 10 m x 10 m. The expected load on each column is 4000 kN. Allowable bearing capacity of the soil deposit is 100 kN/m². The type of foundation best suited is
- (A) isolated footing (B) raft foundation
 (C) pile foundation (D) combined footing
- Q.16 For subcritical flow in an open channel, the control section for gradually varied flow profiles is
- (A) at the downstream end (B) at the upstream end
 (C) at both upstream and downstream ends (D) at any intermediate section
- Q.17 Group-I contains dimensionless parameters and Group-II contains the ratios.
- | | |
|--------------------|------------------------------------------------------|
| Group-I | Group-II |
| P. Mach Number | 1. Ratio of inertial force and gravitational force |
| Q. Reynolds Number | 2. Ratio of fluid velocity and velocity of sound |
| R. Weber Number | 3. Ratio of inertial force and viscous force |
| S. Froude Number | 4. Ratio of inertial force and surface tension force |
- The correct match of dimensionless parameters in Group-I with ratios in Group-II is:
- (A) P-3, Q-2, R-4, S-1 (B) P-3, Q-4, R-2, S-1
 (C) P-2, Q-3, R-4, S-1 (D) P-1, Q-3, R-2, S-4
- Q.18 For a two dimensional flow field, the stream function ψ is given as $\psi = \frac{3}{2}(y^2 - x^2)$. The magnitude of discharge occurring between the stream lines passing through points (0,3) and (3,4) is:
- (A) 6 (B) 3 (C) 1.5 (D) 2
- Q.19 An isohyet is a line joining points of
- (A) equal temperature (B) equal humidity
 (C) equal rainfall depth (D) equal evaporation

- Q.20 Some of the water quality parameters are measured by titrating a water sample with a titrant. Group-I gives a list of parameters and Group-II gives the list of titrants.

Group-I	Group-II
P. Alkalinity	1. N/35.5 AgNO_3
Q. Hardness	2. N/40 $\text{Na}_2\text{S}_2\text{O}_3$
R. Chloride	3. N/50 H_2SO_4
S. Dissolved oxygen	4. N/50 EDTA

The correct match of water quality parameters in Group-I with titrants in Group-II is:

- (A) P-1, Q-2, R-3, S-4
(B) P-3, Q-4, R-1, S-2
(C) P-2, Q-1, R-4, S-3
(D) P-4, Q-3, R-2, S-1
- Q.21 A water treatment plant is designed to treat $1 \text{ m}^3/\text{s}$ of raw water. It has 14 sand filters. Surface area of each filter is 50 m^2 . What is the loading rate (in $\frac{\text{m}^3}{\text{day} \cdot \text{m}^2}$) with two filters out of service for routine backwashing? _____
- Q.22 Select the strength parameter of concrete used in design of plain jointed cement concrete pavements from the following choices:
- (A) Tensile strength
(B) Compressive strength
(C) Flexural strength
(D) Shear strength
- Q.23 It was observed that 150 vehicles crossed a particular location of a highway in a duration of 30 minutes. Assuming that vehicle arrival follows a negative exponential distribution, find out the number of time headways greater than 5 seconds in the above observation? _____
- Q.24 For two major roads with divided carriageway crossing at right angle, a full clover leaf interchange with four indirect ramps is provided. Following statements are made on turning movements of vehicles to all directions from both roads. Identify the *correct* statement:
- (A) Merging from left is possible, but diverging to left is not possible.
(B) Both merging from left and diverging to left are possible.
(C) Merging from left is not possible, but diverging to left is possible.
(D) Neither merging from left nor diverging to left is possible.
- Q.25 The latitude and departure of a line AB are +78 m and -45.1 m, respectively. The whole circle bearing of the line AB is:
- (A) 30° (B) 150° (C) 210° (D) 330°

Q. 26 to Q. 55 carry two marks each.

Q.26 The state of 2D-stress at a point is given by the following matrix of stresses:

$$\begin{bmatrix} \sigma_{xx} & \sigma_{xy} \\ \sigma_{xy} & \sigma_{yy} \end{bmatrix} = \begin{bmatrix} 100 & 30 \\ 30 & 20 \end{bmatrix} \text{MPa}$$

What is the magnitude of maximum shear stress in MPa?

- (A) 50 (B) 75 (C) 100 (D) 110

Q.27 Find the magnitude of the error (correct to two decimal places) in the estimation of following integral using Simpson's $\frac{1}{3}$ Rule. Take the step length as 1. _____

$$\int_0^4 (x^4 + 10) dx$$

Q.28 The solution for $\int_0^{\pi/6} \cos^4 3\theta \sin^3 6\theta d\theta$ is:

- (A) 0 (B) $\frac{1}{15}$ (C) 1 (D) $\frac{8}{3}$

Q.29 Find the value of λ such that the function $f(x)$ is a valid probability density function. _____

$$f(x) = \begin{cases} \lambda(x-1)(2-x) & \text{for } 1 \leq x \leq 2 \\ 0 & \text{otherwise} \end{cases}$$

Q.30 Laplace equation for water flow in soils is given below.

$$\frac{\partial^2 H}{\partial x^2} + \frac{\partial^2 H}{\partial y^2} + \frac{\partial^2 H}{\partial z^2} = 0$$

Head H does not vary in y and z directions.

Boundary conditions are: at $x = 0$, $H = 5$; and $\frac{dH}{dx} = -1$.

What is the value of H at $x = 1.2$? _____

Q.31 All members in the rigid-jointed frame shown are prismatic and have the same flexural stiffness EI . Find the magnitude of the bending moment at Q (in kNm) due to the given loading. _____

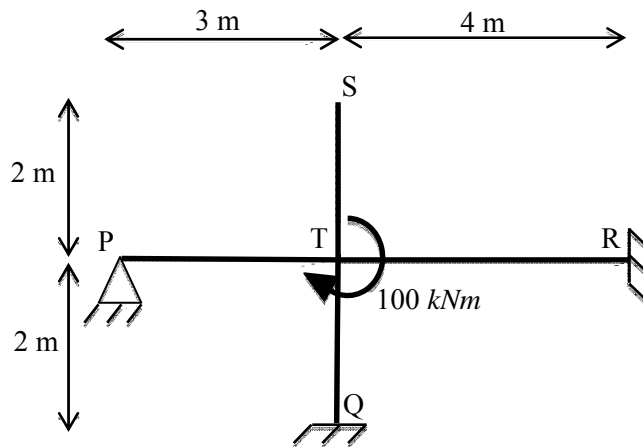

Q.32 A uniform beam ($EI = \text{constant}$) PQ in the form of a quarter-circle of radius R is fixed at end P and free at the end Q , where a load W is applied as shown. The vertical downward displacement, δ_q , at the loaded point Q is given by: $\delta_q = \beta \left(\frac{WR^3}{EI} \right)$. Find the value of β (correct to 4-decimal places). _____

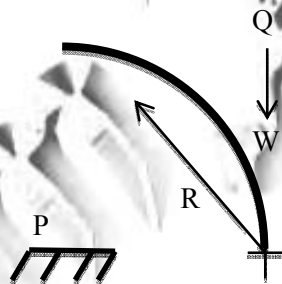

Q.33 A uniform beam weighing 1800 N is supported at E and F by cable ABCD. Determine the tension (in N) in segment AB of this cable (correct to 1-decimal place). Assume the cables ABCD, BE and CF to be weightless. _____

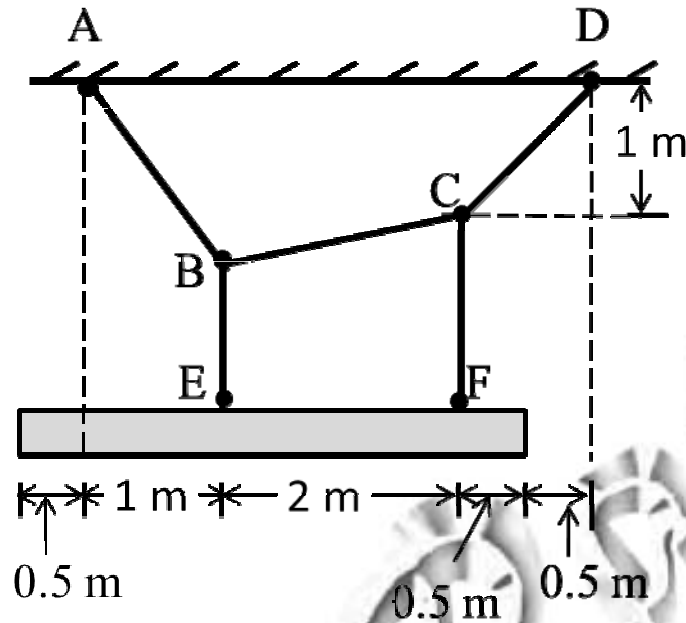

Q.34 Beam PQRS has internal hinges in spans PQ and RS as shown. The beam may be subjected to a moving distributed vertical load of maximum intensity 4 kN/m of any length anywhere on the beam. The maximum absolute value of the shear force (in kN) that can occur due to this loading just to the right of support Q shall be.

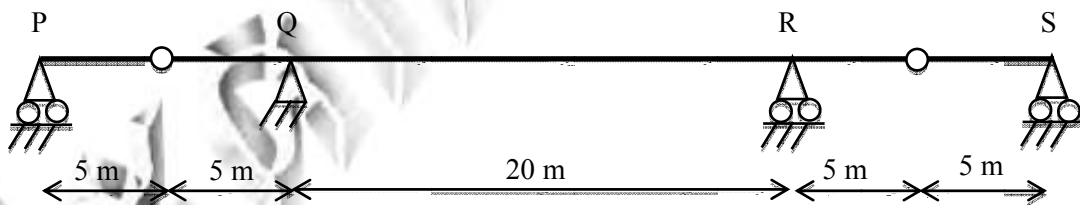

- (A) 30 (B) 40 (C) 45 (D) 55

Q.35 A rectangular concrete beam 250 mm wide and 600 mm deep is pre-stressed by means of 16 high tensile wires, each of 7 mm diameter, located at 200 mm from the bottom face of the beam at a given section. If the effective pre-stress in the wires is 700 MPa , what is the maximum sagging bending moment (in kNm) (correct to 1-decimal place) due to live load that this section of the beam can withstand without causing tensile stress at the bottom face of the beam? Neglect the effect of dead load of beam. _____

Q.36 The soil profile below a lake with water level at elevation = 0 m and lake bottom at elevation = -10 m is shown in the figure, where k is the permeability coefficient. A piezometer (stand pipe) installed in the sand layer shows a reading of +10 m elevation. Assume that the piezometric head is uniform in the sand layer. The quantity of water (in m^3/s) flowing into the lake from the sand layer through the silt layer per unit area of the lake bed is:

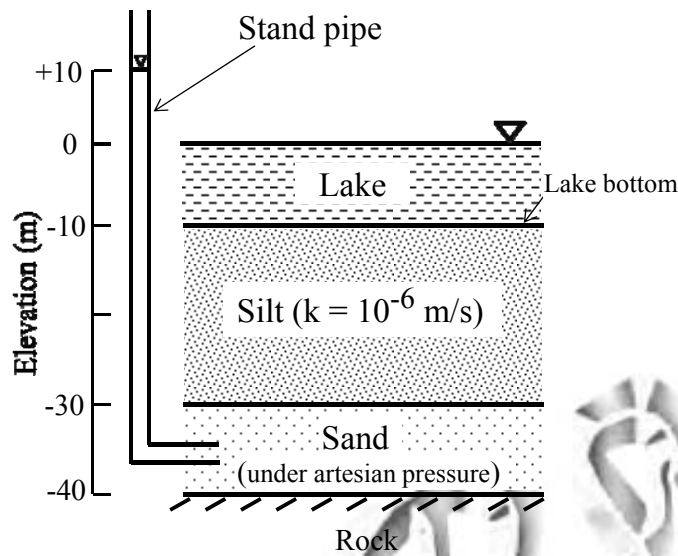

- (A) 1.5×10^{-6}
- (B) 2.0×10^{-6}
- (C) 1.0×10^{-6}
- (D) 0.5×10^{-6}

Q.37 The soil profile above the rock surface for a 25° infinite slope is shown in the figure, where s_u is the undrained shear strength and γ_t is total unit weight. The slip will occur at a depth of

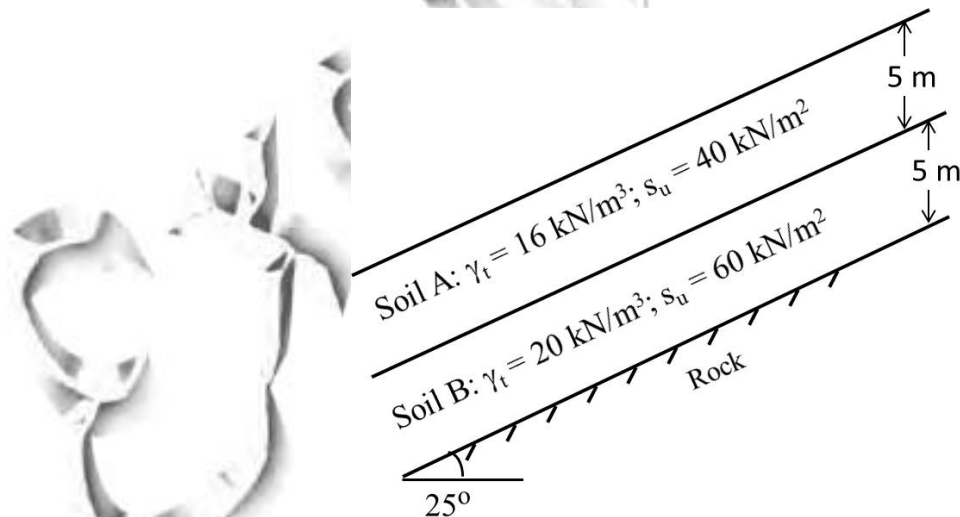

- (A) 8.83 m
- (B) 9.79 m
- (C) 7.83 m
- (D) 6.53 m

- Q.38 Two different soil types (Soil 1 and Soil 2) are used as backfill behind a retaining wall as shown in the figure, where γ_t is total unit weight, and c' and ϕ' are effective cohesion and effective angle of shearing resistance. The resultant active earth force per unit length (in kN/m) acting on the wall is:

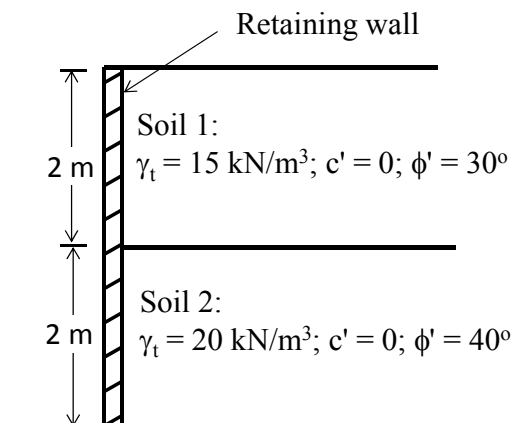

- (A) 31.7 (B) 35.2 (C) 51.8 (D) 57.0
- Q.39 A 2 km long pipe of 0.2 m diameter connects two reservoirs. The difference between water levels in the reservoirs is 8 m. The Darcy-Weisbach friction factor of the pipe is 0.04. Accounting for frictional, entry and exit losses, the velocity in the pipe (in m/s) is:
- (A) 0.63 (B) 0.35 (C) 2.52 (D) 1.25
- Q.40 The normal depth in a wide rectangular channel is increased by 10%. The percentage increase in the discharge in the channel is:
- (A) 20.1 (B) 15.4 (C) 10.5 (D) 17.2
- Q.41 The transplantation of rice requires 10 days and total depth of water required during transplantation is 48 cm. During transplantation, there is an effective rainfall (useful for irrigation) of 8 cm. The duty of irrigation water (in hectares/cumec) is:
- (A) 612 (B) 216 (C) 300 (D) 108
- Q.42 A settling tank in a water treatment plant is designed for a surface overflow rate of $30 \frac{\text{m}^3}{\text{day} \cdot \text{m}^2}$. Assume specific gravity of sediment particles = 2.65, density of water (ρ) = 1000 kg/m^3 , dynamic viscosity of water (μ) = 0.001 N.s/m^2 , and Stokes' law is valid. The approximate minimum size of particles that would be completely removed is:
- (A) 0.01 mm (B) 0.02 mm (C) 0.03 mm (D) 0.04 mm
- Q.43 A student began experiment for determination of 5-day, 20°C BOD on Monday. Since the 5th day fell on Saturday, the final DO readings were taken on next Monday. On calculation, BOD (i.e. 7 day, 20°C) was found to be 150 mg/L. What would be the 5-day, 20°C BOD (in mg/L)? Assume value of BOD rate constant (k) at standard temperature of 20°C as 0.23/day (base e). _____

Q.44 Elevation and temperature data for a place are tabulated below:

Elevation, m	Temperature, °C
4	21.25
444	15.70

Based on the above data, lapse rate can be referred as:

(A) Super-adiabatic (B) Neutral (C) Sub-adiabatic (D) Inversion

Q.45 The percent voids in mineral aggregate (V_{MA}) and percent air voids (V_v) in a compacted cylindrical bituminous mix specimen are 15 and 4.5 respectively. The percent voids filled with bitumen (VFB) for this specimen is:

(A) 24 (B) 30 (C) 54 (D) 70

Q.46 Following bearings are observed while traversing with a compass.

Line	Fore Bearing	Back Bearing
AB	$126^{\circ}45'$	$308^{\circ}00'$
BC	$49^{\circ}15'$	$227^{\circ}30'$
CD	$340^{\circ}30'$	$161^{\circ}45'$
DE	$258^{\circ}30'$	$78^{\circ}30'$
EA	$212^{\circ}30'$	$31^{\circ}45'$

After applying the correction due to local attraction, the corrected fore bearing of line BC will be:

(A) $48^{\circ}15'$ (B) $50^{\circ}15'$ (C) $49^{\circ}45'$ (D) $48^{\circ}45'$

Q.47 A theodolite is set up at station A and a 3 m long staff is held vertically at station B. The depression angle reading at 2.5 m marking on the staff is $6^{\circ}10'$. The horizontal distance between A and B is 2200 m. Height of instrument at station A is 1.1 m and R.L. of A is 880.88 m. Apply the curvature and refraction correction, and determine the R.L. of B (in m). _____

Common Data Questions

Common Data for Questions 48 and 49:

A propped cantilever made of a prismatic steel beam is subjected to a concentrated load P at mid span as shown.

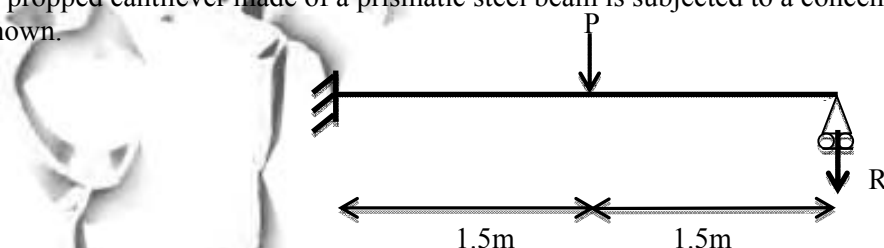

Q.48 If load $P = 80 \text{ kN}$, find the reaction R (in kN) (correct to 1-decimal place) using elastic analysis.

Q.49 If the magnitude of load P is increased till collapse and the plastic moment carrying capacity of steel beam section is 90 kNm , determine reaction R (in kN) (correct to 1-decimal place) using plastic analysis. _____

Common Data for Questions 50 and 51:

For a portion of national highway where a descending gradient of 1 in 25 meets with an ascending gradient of 1 in 20, a valley curve needs to be designed for a vehicle travelling at 90 kmph based on the following conditions.

- (i) headlight sight distance equal to the stopping sight distance (SSD) of a level terrain considering length of valley curve $>$ SSD.
- (ii) comfort condition with allowable rate of change of centrifugal acceleration = 0.5 m/sec^3 .

Assume total reaction time = 2.5 seconds; coefficient of longitudinal friction of the pavement = 0.35; height of head light of the vehicle = 0.75 m; and beam angle = 1° .

Q.50 What is the length of valley curve (in m) based on the head light sight distance condition?

Q.51 What is the length of valley curve (in m) based on the comfort condition? _____

Linked Answer Questions**Statement for Linked Answer Questions 52 and 53:**

A multistory building with a basement is to be constructed. The top 4 m consists of loose silt, below which dense sand layer is present up to a great depth. Ground water table is at the surface. The foundation consists of the basement slab of 6 m width which will rest on the top of dense sand as shown in the figure. For dense sand, saturated unit weight = 20 kN/m^3 , and bearing capacity factors $N_q = 40$ and $N_\gamma = 45$. For loose silt, saturated unit weight = 18 kN/m^3 , $N_q = 15$ and $N_\gamma = 20$. Effective cohesion c' is zero for both soils. Unit weight of water is 10 kN/m^3 . Neglect shape factor and depth factor.

Average elastic modulus E and Poisson's ratio μ of dense sand is $60 \times 10^3 \text{ kN/m}^2$ and 0.3 respectively.

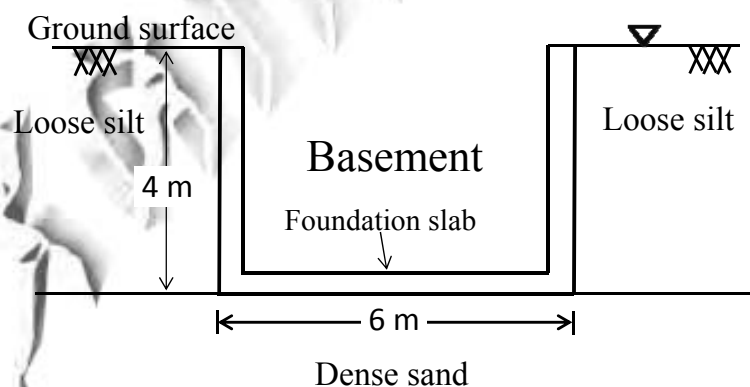

Q.52 Using factor of safety = 3, the net safe bearing capacity (in kN/m^2) of the foundation is:

- (A) 610 (B) 320 (C) 983 (D) 693

Q.53 The foundation slab is subjected to vertical downward stresses equal to net safe bearing capacity derived in the above question. Using influence factor $I_f = 2.0$, and neglecting embedment depth and rigidity corrections, the immediate settlement of the dense sand layer will be:

- (A) 58 mm (B) 111 mm (C) 126 mm (D) 179 mm

Statement for Linked Answer Questions 54 and 55:

At a station, Storm I of 5 hour duration with intensity 2 cm/h resulted in a runoff of 4 cm and Storm II of 8 hour duration resulted in a runoff of 8.4 cm. Assume that the ϕ -index is the same for both the storms.

Q.54 The ϕ -index (in cm/h) is:

- (A) 1.2 (B) 1.0 (C) 1.6 (D) 1.4

Q.55 The intensity of storm II (in cm/h) is:

- (A) 2.00 (B) 1.75 (C) 1.50 (D) 2.25

General Aptitude (GA) Questions**Q. 56 – Q. 60 carry one mark each.**

Q.56 A number is as much greater than 75 as it is smaller than 117. The number is:

- (A) 91 (B) 93 (C) 89 (D) 96

Q.57 The professor ordered to the students to go out of the class.

I II III IV

Which of the above underlined parts of the sentence is grammatically incorrect?

- (A) I (B) II (C) III (D) IV

Q.58 Which of the following options is the closest in meaning to the word given below:

Primeval

- (A) Modern (B) Historic
(C) Primitive (D) Antique

Q.59 Friendship, no matter how _____ it is, has its limitations.

- (A) cordial
(B) intimate
(C) secret
(D) pleasant

Q.60 Select the pair that best expresses a relationship similar to that expressed in the pair:

Medicine: Health

- (A) Science: Experiment (B) Wealth: Peace
(C) Education: Knowledge (D) Money: Happiness

Q. 61 to Q. 65 carry two marks each.

Q.61 X and Y are two positive real numbers such that $2X + Y \leq 6$ and $X + 2Y \leq 8$. For which of the following values of (X, Y) the function $f(X, Y) = 3X + 6Y$ will give maximum value?

- (A) $(4/3, 10/3)$
 (B) $(8/3, 20/3)$
 (C) $(8/3, 10/3)$
 (D) $(4/3, 20/3)$

Q.62 If $|4X - 7| = 5$ then the values of $2|X| - |-X|$ is:

- (A) 2, 1/3 (B) 1/2, 3 (C) 3/2, 9 (D) 2/3, 9

Q.63 Following table provides figures (in rupees) on annual expenditure of a firm for two years - 2010 and 2011.

Category	2010	2011
Raw material	5200	6240
Power & fuel	7000	9450
Salary & wages	9000	12600
Plant & machinery	20000	25000
Advertising	15000	19500
Research & Development	22000	26400

In 2011, which of the following two categories have registered increase by same percentage?

- (A) Raw material and Salary & wages
 (B) Salary & wages and Advertising
 (C) Power & fuel and Advertising
 (D) Raw material and Research & Development

Q.64 A firm is selling its product at Rs. 60 per unit. The total cost of production is Rs. 100 and firm is earning total profit of Rs. 500. Later, the total cost increased by 30%. By what percentage the price should be increased to maintain the same profit level.

- (A) 5 (B) 10 (C) 15 (D) 30

Q.65 Abhishek is elder to Savar.
 Savar is younger to Anshul.

Which of the given conclusions is logically valid and is inferred from the above statements?

- (A) Abhishek is elder to Anshul
 (B) Anshul is elder to Abhishek
 (C) Abhishek and Anshul are of the same age
 (D) No conclusion follows

END OF THE QUESTION PAPER

GATE 2013 : Answer keys for CE - Civil Engineering

Paper	Q.No	Key(s)/Value(s)
CE	1	0.5
CE	2	16
CE	3	D
CE	4	B
CE	5	C
CE	6	A
CE	7	46 to 47
CE	8	A
CE	9	D
CE	10	0
CE	11	70 to 72
CE	12	C
CE	13	C
CE	14	C
CE	15	C
CE	16	A
CE	17	C
CE	18	B
CE	19	C
CE	20	B
CE	21	143 to 145
CE	22	C
CE	23	Marks to All
CE	24	B
CE	25	D
CE	26	A
CE	27	0.52 to 0.55
CE	28	B
CE	29	6
CE	30	3.8
CE	31	25
CE	32	0.785 to 0.786
CE	33	1310 to 1313
CE	34	C
CE	35	85.5 to 86.5

Paper	Q.No	Key(s)/Value(s)
CE	36	D
CE	37	A
CE	38	A
CE	39	A
CE	40	D
CE	41	B
CE	42	B
CE	43	127 to 132
CE	44	A
CE	45	D
CE	46	D
CE	47	641.9 to 642.3
CE	48	25
CE	49	60
CE	50	308 to 311
CE	51	106 to 107
CE	52	Marks to All
CE	53	Marks to All
CE	54	A
CE	55	D
CE	56	D
CE	57	B
CE	58	C
CE	59	B
CE	60	C
CE	61	A
CE	62	B
CE	63	D
CE	64	A
CE	65	D