

Q. No. 1 – 25 Carry One Mark Each

1. The estimate of $\int_{0.5}^{1.5} \frac{dx}{x}$ obtained using Simpson's rule with three-point function evaluation exceeds the exact value by
 (A) 0.235 (B) 0.068 (C) 0.024 (D) 0.012

Answer: - (D)

Exp:- Exact value of $\int_{0.5}^{1.5} \frac{1}{x} dx = 1.0986$

Using Simpson's rule, in threepoint form, $h = \frac{b-a}{2} = \frac{1.5-0.5}{2} = 0.5$

So, x 0.5 1 1.5
 y 2 1 0.67

$\int \frac{1}{x} dx = \frac{h}{3} [y_0 + y_n + 4y_1] = \frac{0.5}{3} = \frac{0.5}{3} [2 + 0.67 + 4 \times 3] = 1.1116$

It exceeds exact by ≈ 0.012

2. The annual precipitation data of a city is normally distributed with mean and standard deviation as 1000 mm and 200 mm, respectively. The probability that the annual precipitation will be more than 1200 mm is
 (A) <50% (B) 50% (C) 75% (D) 100%

Answer: (A)

Exp:- $1 - P(Z) = 1 - P\left(\frac{1200 - 1000}{200}\right) = 1 - P\left(\frac{1}{T}\right) = 0.159 < 50\%$

3. The infinite series $1 + x + \frac{x^2}{2!} + \frac{x^3}{3!} + \frac{x^4}{4!} + \dots$ corresponds to
 (A) $\sec x$ (B) e^x (C) $\cos x$ (D) $1 + \sin^2 x$

Answer: (B)

Exp:- e^x

[Put $x=2$ in given equation which comes to about 7 and $e^2 = 7$]

4. The Poisson's ratio is defined as

(A) $\frac{\text{axial stress}}{\text{lateral stress}}$

(B) $\frac{\text{lateral strain}}{\text{axial strain}}$

(C) $\frac{\text{lateral stress}}{\text{axial stress}}$

(D) $\frac{\text{axial strain}}{\text{lateral strain}}$

Answer: (B)

Exp:- $\mu = -\frac{\frac{dy}{y}}{\frac{dx}{x}} = \text{Poisson ratio}$

5. The following statements are related to bending of beams:
- The slope of the bending moment diagram is equal to the shear force
 - The slope of the shear force diagram is equal to the load intensity
 - The slope of the curvature is equal to the flexural rotation
 - The second derivative of the deflection is equal to the curvature
- The only FALSE statement is
- (A) I (B) II (C) III (D) IV

Answer: (C)

Exp:- $\frac{dM}{dx} = V$ (shear force)

$\frac{dV}{dx} = w$ (load)

$\frac{d^2y}{dx^2} = \psi$ (curvature)

6. If a small concrete cube is submerged deep in still water in such a way that the pressure exerted on all faces of the cube is p , then the maximum shear stress developed inside the cube is
- (A) 0 (B) $\frac{p}{2}$ (C) p (D) $2p$

Answer: (A)

Exp:- $\sigma_x = \sigma_y = \sigma_z = P$

and $\tau_{xy} = 0$ (only normal forces act over it)

so, $\tau_{\theta} = \frac{\sigma_x - \sigma_y}{2} \sin 2\theta - \tau_{xy} \cos 2\theta = 0$

$\tau_{\max} = \sqrt{\left(\frac{\sigma_x - \sigma_y}{2}\right)^2 + \tau_{xy}^2} = 0$

7. As per IS 456:2000, in the Limit State Design of a flexural member, the strain in reinforcing bars under tension at ultimate state should not be less than
- (A) $\frac{f_y}{E_x}$ (B) $\frac{f_y}{E_x} + 0.002$ (C) $\frac{f_y}{1.15E_x}$ (D) $\frac{f_y}{1.15E_x} + 0.002$

Answer: (D)

Exp:- [From IS 456 : 2000]

8. Which one of the following is categorised as a long-term loss of prestress in a prestressed concrete member?
- (A) Loss due to elastic shortening (B) Loss due to friction
(C) Loss due to relaxation of strands (D) Loss due to anchorage slip

Answer: (C)

Exp:- Loss due to relaxation, shrinkage, and creep are time dependent loss

9. In a steel plate with bolted connections, the rupture of the net section is a mode of failure under
 (A) Tension (B) Compression (C) Flexure (D) Shear

Answer: (A)

10. The ratio of the theoretical critical buckling load for a column with fixed ends to that of another column with the same dimensions and material, but with pinned ends, is equal to
 (A) 0.5 (B) 1.0 (C) 2.0 (D) 4.0

Answer: (D)

Exp:- For fixed end column, $P_{C_1} = \frac{4\pi^2 EI}{L^2}$; For pinned end column, $P_{C_2} = \frac{\pi^2 EI}{L^2}$

Hence, $\frac{P_{C_1}}{P_{C_2}} = 4$

11. The effective stress friction angle of a saturated, cohesionless soil is 38° . The ratio of shear stress to normal effective stress on the failure plane is
 (A) 0.781 (B) 0.616 (C) 0.488 (D) 0.438

Answer: (A)

Exp:- $\tau = C + \sigma \tan \phi$

$C = 0 \rightarrow$ cohesionless soils

$\tan \phi = \tan 38^\circ = 0.781$

So, $\tau = \sigma \times 0.781 \Rightarrow \frac{\tau}{\sigma} = 0.781$

12. Two series of compaction tests were performed in the laboratory on an inorganic clayey soil employing two different levels of compaction energy per unit volume of soil. With regard to the above tests, the following two statements are made.

- I. The optimum moisture content is expected to be more for the tests with higher energy
- II. The maximum dry density is expected to be more for the tests with higher energy

The CORRECT option evaluating the above statements is

- (A) Only I is TRUE (B) Only II is TRUE
- (C) Both I and II are TRUE (D) Neither I nor II is TRUE

Answer: (B)

Exp:- So, OMC is more for test with lesser energy,
 Maximum dry density is more for test with higher energy

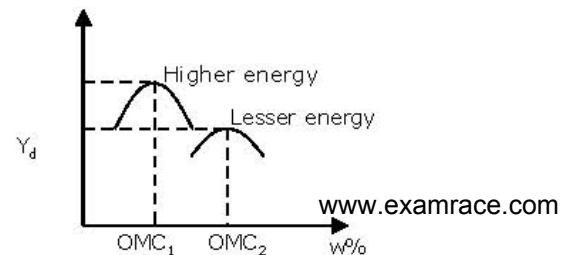

13. As per the Indian Standard soil classification system, a sample of silty clay with liquid limit of 40% and plasticity index of 28% is classified as
 (A) CH (B) CI (C) CL (D) CL-ML

Answer: (B)

Exp:- LL = 40% and PI = 28%

As per IS CODE,

A line, $PI = 0.73(LL - 20) = 14.6 < (28.1 \text{ given})$

so above a line and $20\% < LL = 40\% < 50\%$

So, 'CI'

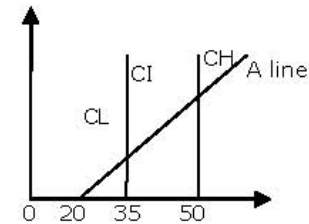

14. A smooth rigid retaining wall moves as shown in the sketch causing the backfill material to fail. The backfill material is homogeneous and isotropic, and obeys the Mohr-Coulomb failure criterion. The major principal stress is

- (A) Parallel to the wall face and acting downwards
 (B) Normal to the wall face
 (C) Oblique to the wall face acting downwards
 (D) Oblique to the wall face acting upwards

Initial wall position
 Final wall position

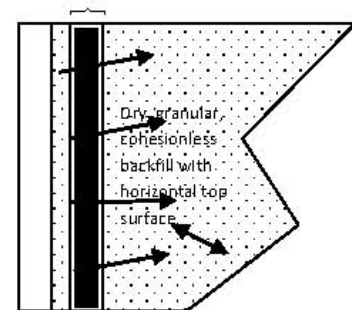

Answer: (B)

15. An embankment is to be constructed with a granular soil (bulk unit weight = 20 kN/m^3) on a saturated clayey silt deposit (undrained shear strength = 25 kPa). Assuming undrained general shear failure and bearing capacity factor of 5.7, the maximum height (in m) of the embankment at the point of failure is
 (A) 7.1 (B) 5.0 (C) 4.5 (D) 2.5

Answer: (A)

16. A trapezoidal channel is 10.0 m wide at the base and has a side slope of 4 horizontal to 3 vertical. The bed slope is 0.002. The channel is lined with smooth concrete (Manning's $n = 0.012$). The hydraulic radius (in m) for a depth of flow of 3.0 m is
 (A) 20.0 (B) 3.5 (C) 3.0 (D) 2.1

Answer: (D)

Exp:- Top width = $4 + 10 + 4 = 18 \text{ m}$

$$\text{So, } A = \frac{1}{2} [10 + 18] \times 3 = 42 \text{ m}^2$$

$$\text{Side length} = \sqrt{3^2 + 4^2} = 5$$

$$\text{Perimeters, } P = 2 \times 5 + 10 = 20$$

$$\text{Hydraulic Radius, } R = \frac{A}{P} = \frac{42}{20} = 2.1$$

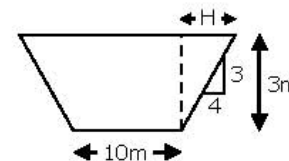

17. A rectangular open channel of width 5.0 m is carrying a discharge of $100 \text{ m}^3 / \text{s}$. The Froude number of the flow is 0.8. The depth of flow (in m) in the channel is
 (A) 4 (B) 5 (C) 16 (D) 20

Answer: (A)

Exp:- $Q = 100 \text{ m}^3 / \text{s}$

$$B = 5\text{m}; F_r = \frac{V}{\sqrt{gd}} = 0.8$$

$$\Rightarrow \frac{V}{\sqrt{gd}} = 0.8 \Rightarrow \frac{Q}{Bd\sqrt{gd}} = 0.8 \Rightarrow \text{solving we get } d = 4\text{m}$$

18. The circular water pipes shown in the sketch are flowing full. The velocity of flow (in m/s) in the branch pipe "R" is

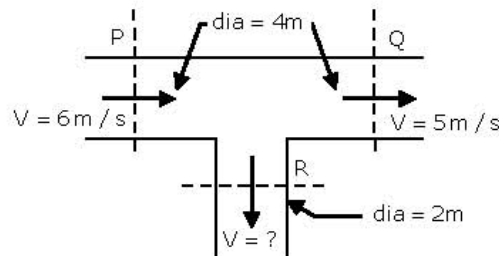

- (A) 3 (B) 4 (C) 5 (D) 6

Answer: (B)

Exp:- Using continuity equation $\Rightarrow (Av)_p = (Av)_R + (Av)_Q$

$$\Rightarrow \frac{\pi}{4} \times 4^2 \times 6 = \frac{\pi}{4} \times 2^2 \times V + \frac{\pi}{4} \times 4^2 \times 5 \Rightarrow \text{Solving } V = 4 \text{ m/s}$$

19. The ratio of actual evapo-transpiration to potential evapo-transpiration is in the range

- (A) 0.0 to 0.4 (B) 0.6 to 0.9 (C) 0.0 to 1.0 (D) 1.0 to 2.0

Answer: (C)

20. A sample of domestic sewage is digested with silver sulphate, sulphuric acid, potassium dichromate and mercuric sulphate in chemical oxygen demand (COD) test. The digested sample is then titrated with standard ferrous ammonium sulphate (FAS) to determine the un-reacted amount of

- (A) Mercuric sulphate (B) Potassium dichromate
 (C) Silver sulphate (D) Sulphuric acid

Answer: (B)

21. **Assertion (a)** : At a manhole, the crown of the outgoing sewer should not be higher than the crown of the incoming sewer.

Reason (r) : Transition from a larger diameter incoming sewer to a smaller diameter outgoing sewer at a manhole should be made.

The CORRECT option evaluating the above statement is:

- (A) Both (a) and (r) are true and (r) is the correct reason for (a)
- (B) Both (a) and (r) are true but (r) is not the correct reason for (a)
- (C) Both (a) and (r) are false
- (D) (a) is true but (r) is false

Answer: (A)

22. Two major roads with two lanes each are crossing in an urban area to form an un-controlled intersection. The number of conflict points when both roads are one-way is "X" and when both roads are two-way is "Y". The ratio of X to Y is
- (A) 0.25 (B) 0.33 (C) 0.50 (D) 0.75

Answer: (A)

Exp:- Number of conflict points for one-way roads = 6 (x)
Number of conflict points for two-way roads = 24 (y)

$$\text{So, } \frac{x}{y} = \frac{6}{24} = 0.25$$

23. Two bitumen samples "X" and "Y" have softening points 45°C and 60°C, respectively. Consider the following statements:
- I. Viscosity of "X" will be higher than that of "Y" at the same temperature
 - II. Penetration value of "X" will be lesser than that of "Y" under standard conditions.

The CORRECT option evaluating the above statements is

- (A) Both I and II are TRUE
- (B) I is FALSE and II is TRUE
- (C) Both I and II are FALSE
- (D) I is TRUE and II FALSE

Answer: (C)

Exp:- Lower the softening, lower the viscosity 2nd higher the penetration value

24. Road roughness is measured using
- (A) Benklman beam
 - (B) Bump integrator
 - (C) Dynamic cone penetrometer
 - (D) Falling weight deflectometer

Answer: (B)

25. Which of the following errors can be eliminated by reciprocal measurements in differential leveling?
- I. Error due to earth's curvature
 - II. Error due to atmospheric-refraction
- (A) Both I and II (B) I only (C) II only (D) Neither I nor II

Answer: (A)

26. The error in $\left. \frac{d}{dx} f(x) \right|_{x=x_0}$ for a continuous function estimated with $h = 0.03$ using the central difference formula $\left. \frac{d}{dx} f(x) \right|_{x=x_0} \approx \frac{f(x_0 + h) - f(x_0 - h)}{2h}$, is 2×10^{-3} . The values of x_0 and $f(x_0)$ are 19.78 and 500.01, respectively. The corresponding error in the central difference estimate for $h = 0.02$ is approximately
 (A) 1.3×10^{-4} (B) 3.0×10^{-4} (C) 4.5×10^{-4} (D) 9.0×10^{-4}

Answer: (A)

27. In an experiment, positive and negative values are equally likely to occur. The probability of obtaining at most one negative value in five trials is
 (A) $\frac{1}{32}$ (B) $\frac{2}{32}$ (C) $\frac{3}{32}$ (D) $\frac{6}{32}$

Answer: (D)

Exp:- $P = q = \frac{1}{2}$

$$\text{Probability} = {}^n C_r P^r q^{n-r} = {}^5 C_0 \left(\frac{1}{2}\right)^0 \left(\frac{1}{2}\right)^5 + {}^5 C_1 \left(\frac{1}{2}\right)^1 \left(\frac{1}{2}\right)^4 = \frac{6}{32}$$

28. The eigen values of matrix $\begin{bmatrix} 9 & 5 \\ 5 & 8 \end{bmatrix}$ are
 (A) -2.42 and 6.86 (B) 3.48 and 13.53
 (C) 4.70 and 6.86 (D) 6.86 and 9.50

Answer: (B)

Exp:- $\begin{vmatrix} 9 - \lambda & 5 \\ 5 & 8 - \lambda \end{vmatrix} = 0 \Rightarrow (9 - \lambda)(8 - \lambda) = 25 \Rightarrow \lambda = 3.48, 13.53$

29. For the parallelogram OPQR shown in the sketch, $\overline{OP} = a\hat{i} + b\hat{j}$ and $\overline{OR} = c\hat{i} + d\hat{j}$. The area of the parallelogram is

- (A) $ad - bc$
 (B) $ac + bd$
 (C) $ad + bc$
 (D) $ab - cd$

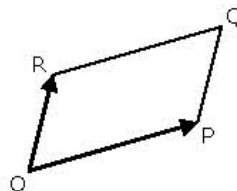

Answer: (A)

Exp:- Area of parallelogram, $A = \overline{OP} \times \overline{OR} = K(ad - bc)$ $\overline{OP} \times \overline{OR} = \begin{vmatrix} \hat{i} & \hat{j} & \hat{k} \\ a & b & 0 \\ c & d & 0 \end{vmatrix}$

$|A| = ad - bc$

30. The solution of the ordinary differential equation $\frac{dy}{dx} + 2y = 0$ for the boundary condition, $y = 5$ at $x = 1$ is

(A) $y = e^{-2x}$ (B) $y = 2e^{-2x}$ (C) $y = 10.95e^{-2x}$ (D) $y = 36.95e^{-2x}$

Answer: (D)

Exp:- Given, $\frac{dy}{dx} + 2y = 0$ and $y = 5$ at $x = 1$

$(D + 2)y = 0 \Rightarrow D = -2$ \therefore The solution is $y = C_1 e^{-2x}$

Now, $x = 1 \Rightarrow 5 = C_1 e^{-2} \Rightarrow 5e^2 = C_1 = 36.95$

\therefore The required solution is $y = 36.95e^{-2x}$

31. A simply supported beam is subjected to a uniformly distributed load of intensity w per unit length on half of the span from one end. The length of the span and the flexural stiffness are denoted as l and EI , respectively. The deflection at mid-span of the beam is

(A) $\frac{5}{6144} \frac{wl^4}{EI}$ (B) $\frac{5}{768} \frac{wl^4}{EI}$ (C) $\frac{5}{384} \frac{wl^4}{EI}$ (D) $\frac{5}{192} \frac{wl^4}{EI}$

Answer: (B)

32. The sketch shows a column with a pin at the base and rollers at the top. It is subjected to an axial force P and a moment M at mid-height. The reaction(s) at R is/are

(A) A vertical force equal to P
 (B) A vertical force equal to $P/2$
 (C) A vertical force equal to P and a horizontal force equal to M/h
 (D) A vertical force equal to $P/2$ and a horizontal force equal to M/h

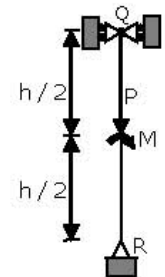

Answer: (C)

33. A concrete beam prestressed with a parabolic tendon is shown in the sketch. The eccentricity of the tendon is measured from the centroid of the cross-section. The applied prestressing force at service is 1620kN. The uniformly distributed load of 45kN/m includes the self-weight

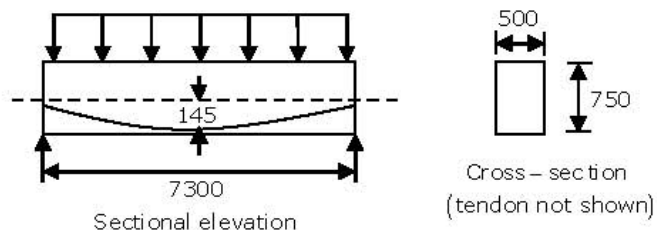

All dimensions are in mm

The stress (in N/mm^2) in the bottom fibre at mid-span is

(A) Tension 2.90 (B) Compressive 2.90
 (C) Tensile 4.32 (D) Compressive 4.32

Answer: (B)

Exp:- $A = 375 \times 10^3 \text{ mm}^2$

$$\frac{I}{y} = z = \frac{bd^2}{6} = 46875 \times 10^3 \text{ mm}^3$$

$$M_b = \text{moment due to UDL} = \frac{wl^2}{8} = 299.76 \times 10^6 \text{ Nmm}$$

$$\text{So, stress at bottom at mid-span} = \frac{-P}{A} - \frac{P_e}{z} + \frac{M_b}{2} = -2.90 \text{ N/mm}^2 \text{ (compressive)}$$

34. A symmetric frame PQR consists of two inclined members PQ and QR, connected at 'Q' with rigid joint, and hinged at 'P' and 'R'. The horizontal length PR is l. If a weight W is suspended at 'Q' the bending moment at 'Q' is

- (A) $\frac{Wl}{2}$ (B) $\frac{Wl}{4}$ (C) $\frac{Wl}{8}$ (D) Zero

Answer: (D)

35. Two plates connected by fillet welds of size 10 mm and subjected to tension, as shown in the sketch. The thickness of each plate is 12 mm. The yield stress and the ultimate tensile stress of steel are 250 MPa and 410 MPa respectively. The welding is done in the workshop ($\gamma_{mw} = 1.25$). As per the Limit State Method of IS 800:2007, the minimum length (rounded off to the nearest higher multiple of 5 mm) of each weld to transmit a force P equal to 270kN is

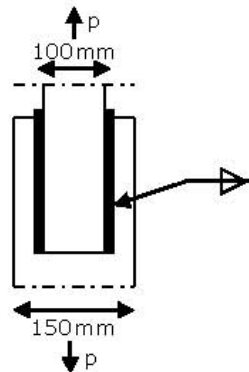

- (A) 100 mm (B) 105 mm (C) 110 mm (D) 115 mm

Answer: (B)

36. Two soil specimens with identical geometric dimensions were subjected to falling head permeability tests in the laboratory under identical conditions. The fall of water head was measured after an identical time interval. The ratio of initial to final water heads for the test involving the first specimen was 1.25. If the coefficient of permeability of the second specimen is 5-times that of the first, the ratio of initial to final water heads in the test involving the second specimen is

- (A) 3.05 (B) 3.80 (C) 4.00 (D) 6.25 www.examrace.com

Answer: (A)

Exp:- For falling head test, $\ln\left(\frac{h_1}{h_2}\right) = \frac{KAt}{\partial L}$

$$\frac{h_1}{h_2} = e^{kd} \left[\alpha = \frac{At}{\partial L} = \text{constant} \right]$$

$$\text{1st specimen, } R_1 = \frac{h_1}{h_2} = 1.25 = e^{kd}$$

$$R_2 = \left(\frac{h_1}{h_2}\right) = e^{5kd} = (e^{kd})^5 = (R_1)^5 = (1.25)^5 = 3.05$$

37. A layer of normally consolidated, saturated silty clay of 1 m thickness is subjected to one-dimensional consolidation under a pressure increment of 20kPa. The properties of the soil are: specific gravity = 2.7, natural moisture content = 45%, compression index = 0.45, and recompression index = 0.05. The initial average effective stress within the layer is 100 kPa. Assuming Terzaghi's theory to be applicable, the primary consolidation settlement (rounded off to the nearest mm) is

(A) 2 mm (B) 9 mm (C) 14 mm (D) 16 mm

Answer: (D)

38. Steady state seepage is taking place through a soil element at Q, 2 m below the ground surface immediately downstream of the toe of an earthen dam as shown in the sketch. The water level in a piezometer installed at P, 500 mm above Q, is at the ground surface. The water level in a piezometer installed at R, 500 mm below Q is 100 mm above the ground surface. The bulk saturated unit weight of the soil is 18 kN/m^3 and the unit weight of water is 9.81 kN/m^3 . The vertical effective stress (in kPa) at Q is

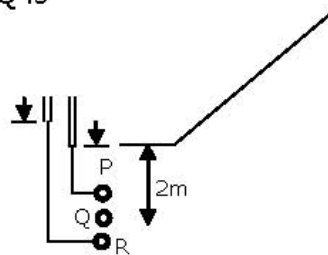

(A) 14.42 (B) 15.89 (C) 16.38 (D) 18.34

Answer: (B)

Exp:- At P, $h = 1.5$; R, $h = 2.6$; So at Q, $h = 2.05$

$$\begin{aligned} \text{So, effective stress at } \theta &= \sigma^1 = \sigma - u = \gamma_{\text{sat}} \times H - \gamma_w \times h \\ &= 18 \times 2 - 9.81 \times 2.05 = 15.89 \text{ kN/m}^2 \end{aligned}$$

39. The top width and the depth of flow in a triangular channel were measured as 4 m and 1 m, respectively. The measured velocities on the centre line at the water surface, 0.2 m and 0.8 m below the surface are 0.7 m/s, 0.6 m/s and 0.4 m/s respectively. Using two-point method of velocity measurement, the discharge (in m^3/s) in the channel is

(A) 1.4 (B) 1.2 (C) 1.0 (D) 0.8

Answer: (C)

Exp:- As per two point method of velocity measurement

$$V_{\text{mean}} = \frac{V_{0.2} + V_{0.8}}{2} = \frac{0.6 + 0.4}{2} = 0.5 \text{ m/s}$$

$$\text{So, } Q = V \times A = 0.5 \times \left[\frac{1}{2} \times 4 \times 1 \right] = 1 \text{ m}^3 / \text{s}$$

40. Group I contains parameters and Group II lists methods/instruments.

Group I		Group II	
P.	Stream-flow velocity	1.	Anemometer
Q.	Evapo-transpiration rate	2.	Penman's method
R.	Infiltration rate	3.	Horton's method
S.	Wind velocity	4.	Current meter

The CORRECT match of Group I with Group II is

(A) P - 1, Q - 2, R - 3, S - 4

(B) P - 4, Q - 3, R - 2, S - 1

(C) P - 4, Q - 2, R - 3, S - 1

(D) P - 1, Q - 3, R - 2, S - 4

Answer: (C)

41. Wheat crop requires 55 cm of water during 120 days of base period. The total rainfall during this period is 100 mm. Assume the irrigation efficiency to be 60%. The area (in ha) of the land which can be irrigated with a canal flow of $0.01 \text{ m}^3 / \text{s}$ is

(A) 13.82

(B) 18.85

(C) 23.04

(D) 230.40

Answer: (A)

42. A water sample has a pH of 9.25. The concentration of hydroxyl ions in the water sample is

(A) $10^{-9.25}$ moles / L

(B) $10^{-7.75}$ mmoles / L

(C) 0.302 mg/L

(D) 3.020 mg/L

Answer: (C)

43. A town is required to treat $4.2 \text{ m}^3 / \text{min}$ of raw water for daily domestic supply. Flocculating particles are to be produced by chemical coagulation. A column analysis indicated that an overflow rate of 0.2 mm/s will produce satisfactory particle removal in a settling basin at a depth of 3.5 m. The required surface area (in m^2) for settling is

(A) 210

(B) 350

(C) 1728

(D) 21000

Answer: (B)

Exp:- Overflow rate = $\frac{Q}{A} \Rightarrow A = \frac{Q}{\text{OR}} = \frac{4.2 \text{ m}^3 / \text{s}}{60 \times 0.2 \times 10^{-3} \text{ m/s}} = 350 \text{ m}^2$

44. A pavement designer has arrived at a design traffic of 100 million standard axles for a newly developing national highway as per IRC:37 guidelines using the following data: design life = 15 years, commercial vehicle count before pavement construction = 4500 vehicles/day, annual traffic growth rate = 8%. The vehicle damage factor used in the calculation was
- (A) 1.53 (B) 2.24 (C) 3.66 (D) 4.14

Answer: (B)

$$\text{Exp:- } mSA = \frac{365A \left[(1+r)^n - 1 \right]}{r} \times VDF$$

$$\Rightarrow 100 \times 10^6 = 365 \times 4500 \frac{\left[(1+0.08)^{15} - 1 \right]}{r} \times V_{DF} \Rightarrow VDF = 2.24$$

45. The following data are related to a horizontal curved portion of a two lane highway: length of curve = 200 m, radius of curve = 300 m and width of pavement = 7.5 m. In order to provide a stopping sight distance (SSD) of 80 m, the set back distance (in m) required from the centre line of the inner lane of the pavement is
- (A) 2.54 (B) 4.55 (C) 7.10 (D) 7.96

Answer: (B)

46. A two-lane urban road with one-way traffic has a maximum capacity of 1800 vehicles/hour. Under the jam condition, the average length occupied by the vehicles is 5.0 m. The speed versus density relationship is linear. For a traffic volume of 1000 vehicles/hour, the density (in vehicles/km) is
- (A) 52 (B) 58 (C) 67 (D) 75

Answer: (C)

47. The horizontal distance between two stations P and Q is 100 m. The vertical angles from P and Q to the top of a vertical tower at T are 3° and 5° above horizontal, respectively. The vertical angles from P and Q to the base of the tower are 0.1° and 0.5° below horizontal, respectively. Stations P, Q, and the tower are in the same vertical plane with P and Q being on the same side of T. Neglecting earth's curvature and atmospheric refraction, the height (in m) of the tower is
- (A) 6.972 (B) 12.387 (C) 12.540 (D) 128.745

Answer: (B)

$$\text{Exp:- } x(\tan 3 + \tan 0.1) = (x - 100)(\tan 5^\circ + \tan 0.5^\circ)$$

$$\Rightarrow x = 228.758$$

$$\text{Height of tower} = 228.758 (\tan 3^\circ + \tan 0.1^\circ)$$

$$= 12.387 \text{ m}$$

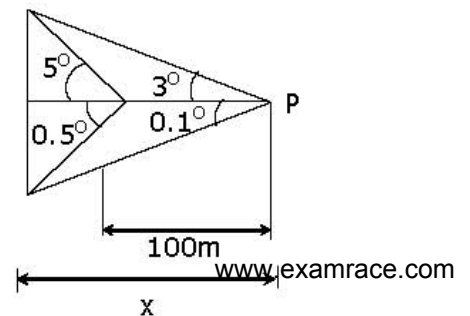

Common Data Questions: 48 & 49

The flow net around a sheet pile wall is shown in the sketch. The properties of the soil are: permeability coefficient = 0.09 m/day (isotropic), specific gravity = 2.70 and void ratio = 0.85. The sheet pile wall and the bottom of the soil are impermeable.

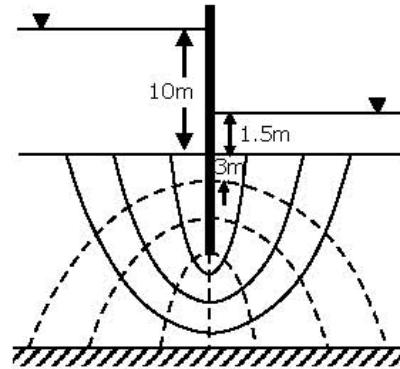

48. The seepage loss (in m^3 per day per unit length of the wall) of water is
 (A) 0.33 (B) 0.38 (C) 0.43 (D) 0.54

Answer: (B)

49. The factor of safety against the occurrence of piping failure is
 (A) 3.55 (B) 2.93 (C) 2.60 (D) 0.39

Answer: (C)

Common Data Questions: 50 & 51

An activated sludge system (sketched below) is operating at equilibrium with the following information. Wastewater related data: flow rate = $500 \text{ m}^3 / \text{hour}$, influent BOD = 150 mg/L , effluent BOD = 10 mg/L . Aeration tank related data: hydraulic retention time = 8 hours, mean-cell-residence time = 240 hours, volume = 4000 m^3 , mixed liquor suspended solids = 2000 mg/L .

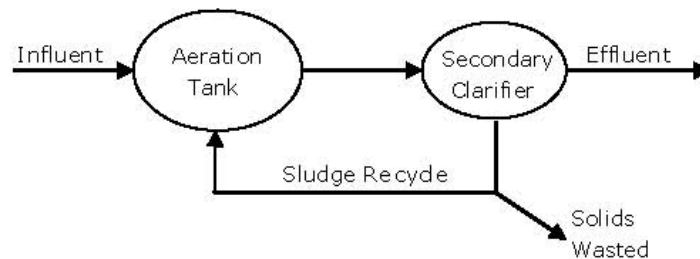

50. The food-to-biomass (F/M) ratio (in kg BOD per kg biomass per day) for the aeration tank is
 (A) 0.015 (B) 0.210 (C) 0.225 (D) 0.240

Answer: (C)

Exp:-
$$\frac{F}{M} = \frac{y_0}{t \times v} = \frac{500 \text{ m}^3 / \text{h} \times 150 \text{ mg/L}}{200 \text{ mg/L} \times 4000} = 9.375 \times 10^{-3} \text{ kg/h} = 0.225 \text{ kg/day}$$
 www.examrace.com

51. The mass (in kg/day) of solids wasted from the system is
 (A) 24000 (B) 1000 (C) 800 (D) 33

Answer: (A)

Exp:- Mass of solid waste from system = $200 \frac{\text{mg}}{\text{L}} \times 500 \times 10^3 \text{ k / hs} = 10 \times 10^8 \times 24 \text{ kg / day}$
 $= 24000 \text{ kg / day}$

Linked Answer Questions: Q.52 to Q.55 Carry Two Marks Each

Statement for Linked Answer Questions: 52 & 53

The cross-section at mid-span of a beam at the edge of a slab is shown in the sketch. A portion of the slab is considered as the effective flange width for the beam. The grades of concrete and reinforcing steel are M25 and Fe415 respectively. The total area of reinforcing bars (A_s) is 4000 mm^2 . At the ultimate limit state x_u denotes the depth of the neutral axis from the top fibre. Treat the section as under-reinforced and flanged ($x_u > 100 \text{ mm}$)

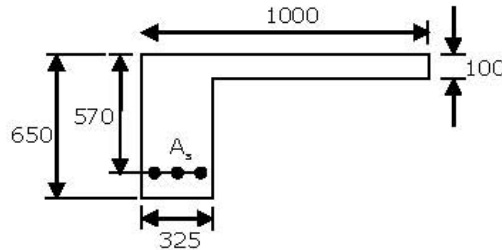

52. The value of x_u (in mm) computed as per the Limit State Method of IS 456:2000 is
 (A) 200.0 (B) 223.3 (C) 236.3 (D) 273.6

Answer: (C)

Exp:- $0.36 f_{ck} b x + 0.45 f_{ck} b_f D_f = 0.87 f_y A_{st}$

$$\Rightarrow 0.36 \times 25 \times 325 \times x_u + 0.45 \times 25 \times (1000 - 325) \times 100 = 0.87 \times 415 \times 4000$$

$$x_u = 236.3 \text{ mm}$$

53. The ultimate moment capacity (in kNm) of the section, as per the Limit State Method of IS 456:2000 is
 (A) 475.2 (B) 717.0 (C) 756.4 (D) 762.5

Answer: (B)

Statement for Linked Answer Questions: 54 & 55

The drainage area of a watershed is 50 km^2 . The ϕ index is 0.5 cm/hour and the base flow at the outlet is $10 \text{ m}^3 / \text{s}$. One hour unit hydrograph (unit depth = 1 cm) of the watershed is triangular in shape with a time base of 15 hours. The peak ordinate occurs at 5 hours. www.civildatas.com

54. The peak ordinate (in $\text{m}^3 / \text{s} / \text{cm}$) of the unit hydrograph is
 (A) 10.00 (B) 18.52 (C) 37.03 (D) 185.20

Answer: (B)

Exp:- $\frac{1}{2} \times B \times H = \text{Area} \times (1\text{cm rainfall})$

$$\Rightarrow \frac{1}{2} \times 15 \times 3600 \times H = 50 \times 10^6 \times 0.01 \Rightarrow H = 18.52 \text{ m}^3 / \text{s.cm}$$

55. For a storm of depth of 5.5 cm and duration of 1 hour, the peak ordinate (in m^3 / s) of the hydrograph is
 (A) 55.00 (B) 82.60 (C) 92.60 (D) 102.60

Answer: (C)

Exp:- $\text{Runoff} = \text{Rainfall} - \phi = 5.5 - 0.5 = 5 \text{ cm}$

$\text{Peak of Hydrograph} = \text{Peak of unit Hydrograph} \times 5 \text{ cm}$

$$= 18.52 \frac{\text{m}^3 / \text{s}}{\text{cm}} \times 5 \text{ cm} = 18.52 \text{ m}^3 / \text{sec}$$

Q. No. 56 – 60 Carry One Mark Each

56. Choose the most appropriate alternative from the options given below to complete the following sentence:
Despite several _____ the mission succeeded in its attempt to resolve the conflict.
 (A) attempts (B) setbacks (C) meetings (D) delegations

Answer: (B)

57. The cost function for a product in a firm is given by $5q^2$, where q is the amount of production. The firm can sell the product at a market price of Rs.50 per unit. The number of units to be produced by the firm such that the profit is maximized is
 (A) 5 (B) 10 (C) 15 (D) 25

Answer: (A)

Exp:- $\text{Total cost} = 5q^2$

$\text{Sp of 1 unit} = \text{Rs. } 50$

$\text{So, total sp} = 50q$

$P = \text{Profit} = \text{SP} - \text{CP} = 50q - 5q^2$

To maximize P , $\frac{dp}{dq} = 50 - 10q = 0 \Rightarrow q = 5 \text{ units}$

58. Choose the most appropriate alternative from the options given below to complete the following sentence:

Suresh's dog is the one _____ was hurt in the stampede.

- (A) that (B) which (C) who (D) whom 59www.examrace.com

Answer: (A)

59. Choose the grammatically **INCORRECT** sentence:

- (A) They gave us the money back less the service charges of Three Hundred rupees.
- (B) This country's expenditure is not less than that of Bangladesh.
- (C) The committee initially asked for a funding of Fifty Lakh rupees, but later settled for a lesser sum.
- (D) This country's expenditure on educational reforms is very less

Answer: (D)

60. Which one of the following options is the closest in meaning to the word given below?

Mitigate

- (A) Diminish
- (B) Divulge
- (C) Dedicate
- (D) Denote

Answer: (A)

Q. No. 61 – 65 Carry Two Marks Each

61. A political party orders an arch for the entrance to the ground in which the annual convention is being held. The profile of the arch follows the equation $y = 2x - 0.1x^2$ where y is the height of the arch in meters. The maximum possible height of the arch is

- (A) 8 meters
- (B) 10 meters
- (C) 12 meters
- (D) 14 meters

Answer: (B)

Exp:- $y = 2x - 0.1x^2$

$$\frac{dy}{dx} = 2 - 0.2x$$

$$\frac{d^2y}{dx^2} < 0 \therefore y \text{ maximises at } 2 - 0.2x = 0$$

$$\Rightarrow x = 10$$

$$\therefore y = 20 - 10 = 10 \text{ m}$$

62. Wanted Temporary, Part-time persons for the post of Field Interviewer to conduct personal interviews to collect and collate economic data. Requirements: High School-pass, must be available for Day, Evening and Saturday work. Transportation paid, expenses reimbursed.

Which one of the following is the best inference from the above advertisement?

- (A) Gender-discriminatory
- (B) Xenophobic
- (C) Not designed to make the post attractive
- (D) Not gender-discriminatory

Answer: (C)

63. Given the sequence of terms, AD CG FK JP, the next term is
 (A) OV (B) OW (C) PV (D) PW

Answer: (A)

Exp:-

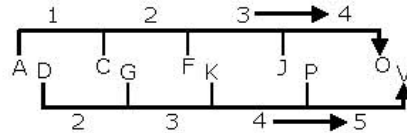

64. Which of the following assertions are CORRECT?

- P: Adding 7 to each entry in a list adds 7 to the mean of the list
 Q: Adding 7 to each entry in a list adds 7 to the standard deviation of the list
 R: Doubling each entry in a list doubles the mean of the list
 S: Doubling each entry in a list leaves the standard deviation of the list unchanged
 (A) P, Q (B) Q, R (C) P, R (D) R, S

Answer: (C)

Exp:- (P) Consider the example,

$$\text{Let entry be } 1, 2, 3, 4; \text{ So, mean} = \frac{1+2+3+4}{4} = 2.5$$

Add 7 to all entry

8, 9, 10, 11

$$\text{Mean} = \frac{8+9+10+11}{4} = 9.5 = 2.5 + (7)$$

(R) Double the entry, 2, 4, 6, 8

$$\text{Mean} = \frac{2+4+6+8}{4} = 5 = 2 \times 2.5$$

65. An automobile plant contracted to buy shock absorbers from two suppliers X and Y. X supplies 60% and Y supplies 40% of the shock absorbers. All shock absorbers are subjected to a quality test. The ones that pass the quality test are considered reliable. Of X's shock absorbers, 96% are reliable. Of Y's shock absorbers, 72% are reliable. The probability that a randomly chosen shock absorber, which is found to be reliable, is made by Y is

- (A) 0.288 (B) 0.334 (C) 0.667 (D) 0.720

Answer: (B)

Exp:-

	x	y
Supply	60%	40%
Reliable	96%	72%
Overall	0.576	0.288

$$\therefore P(x) = \frac{0.288}{0.576 + 0.288} = 0.334$$