

# Flow of Presentation

- What is Self Sensing concrete (SSC)
- Compositions of SSC
- Materials of SSC
- Fabrication of SSC
- Processing of self-sensing concrete
- Mixing Dispersing Processes for SSC
- Fabrication of the electrodes for SSC
- Sensing Mechanism of SSC
- Structural Application of SSC
- Concluding Remarks

# What is Self Sensing concrete (SSC)

- Invented by Professor Deborah Chung in University at Buffalo, State University of New York. (1993)
- The concrete has been modified through the use of admixtures so that it becomes a sensor.



- The sensing property of Self sensing concrete is coupled relation between **Electrical** and **mechanical properties**

# Compositions of SSC

- SSC having highly complex structure, is a **Multi-phase, Multi-scale and Multi-component** composite in nature.
- At **Macroscopic level**, SSC may be considered two phase materials i.e., **Filler phase** and **Concrete matrix phase**.
- At **Microscopic level**, it has a third phase i.e., composed of interface between fillers-concrete matrix and between fillers.

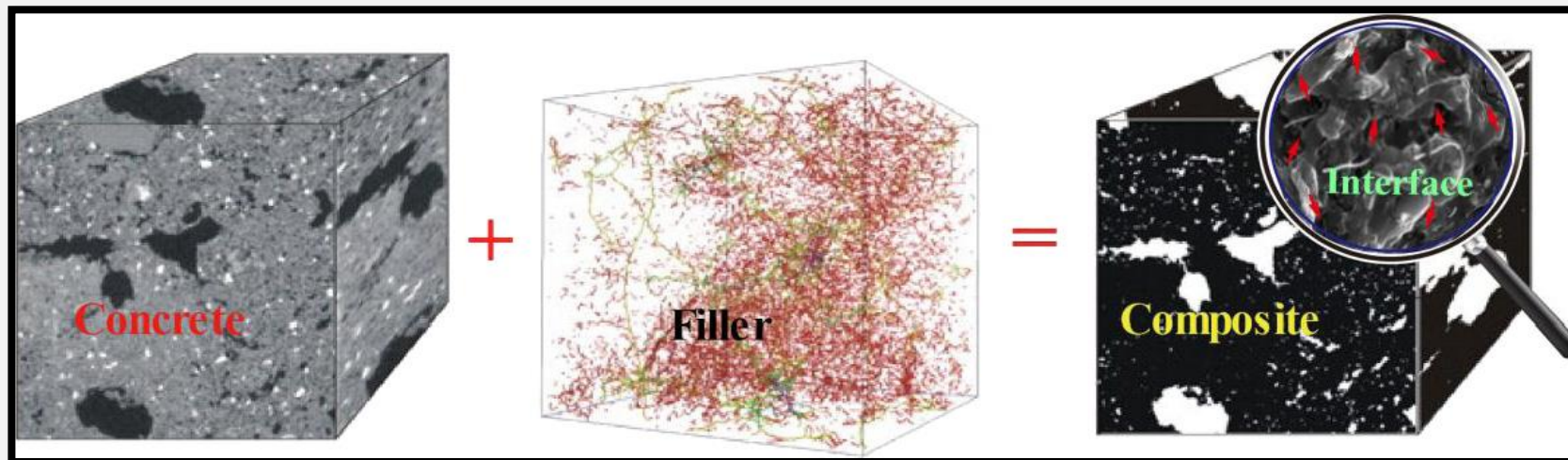

Structure of SSC

# Materials of SSC

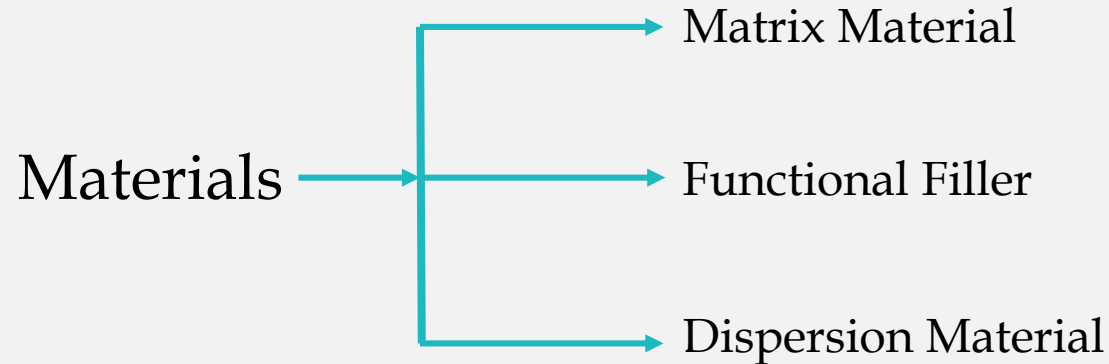

## I. Matrix Materials :

- It holds the function filler together to form the bulk composite, so all types of concrete can be use as matrix of SSC.
- Matrix Materials are cement like Portland Cement, Sulpho-aluminate Cement, Alkali Activated Slag Cement etc., Course Aggregate, Fine Aggregate etc.
- It has poor sensing ability but some properties of concrete matrix have great effect on sensing property like mechanical behavior and electrical conduction.

# Materials of SSC

## II. Functional Filler

- It is an essential component of SSC because it dominates the sensing properties of SSC.
- More than 10 types of function fillers like...
  1. Carbon Fiber (CF)
  2. Carbon Nano Tube (CNT)
  3. Carbon Black(CB)
  4. Steel Slag (SS)
  5. Nickel Powder (NP), etc.

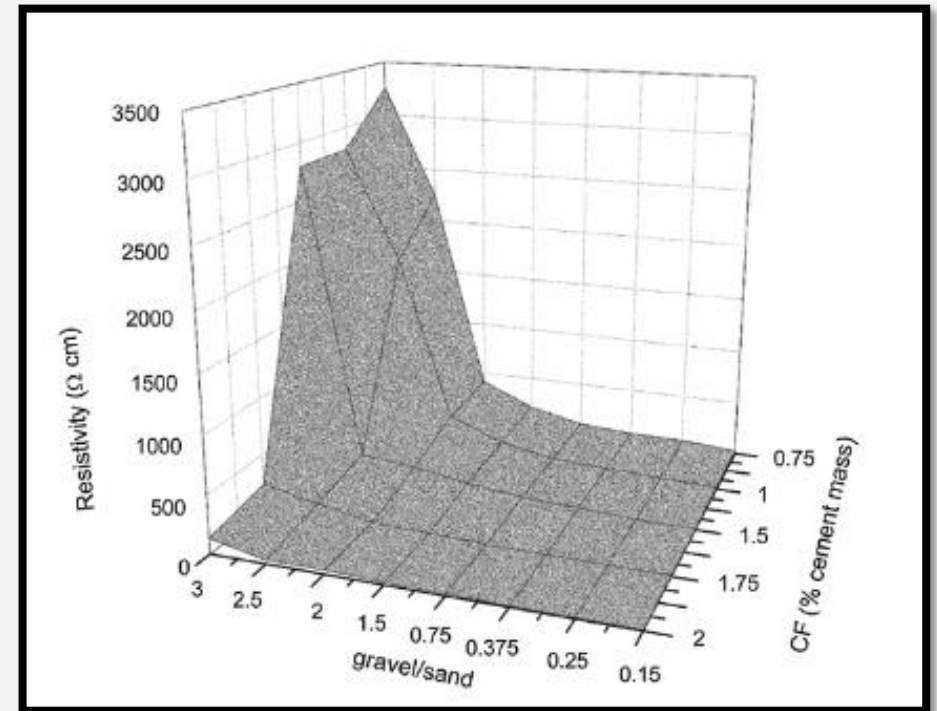

Dependence of electrical resistivity of concrete on Carbon fiber proportion and gravel-sand ration

# Materials of SSC

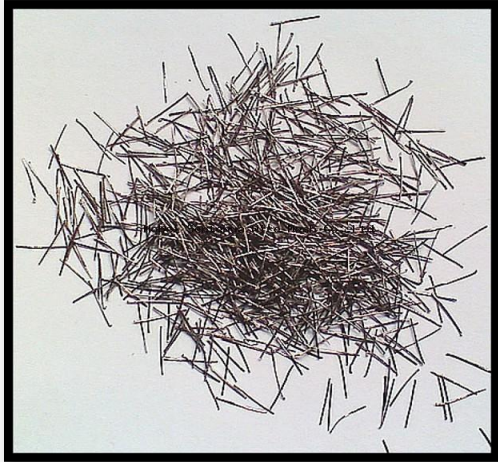

Steel Fiber



Carbon Black

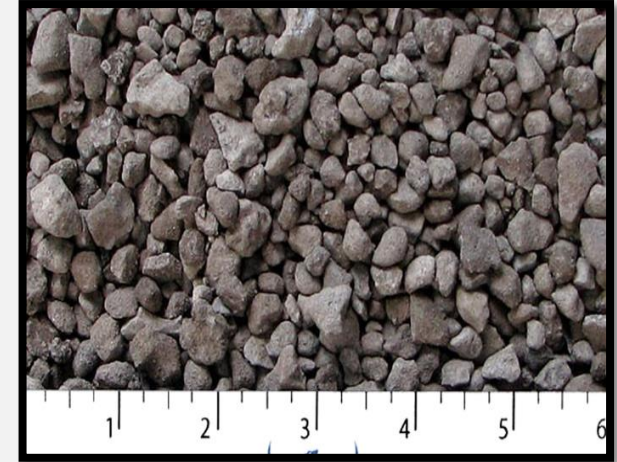

Steel Slag

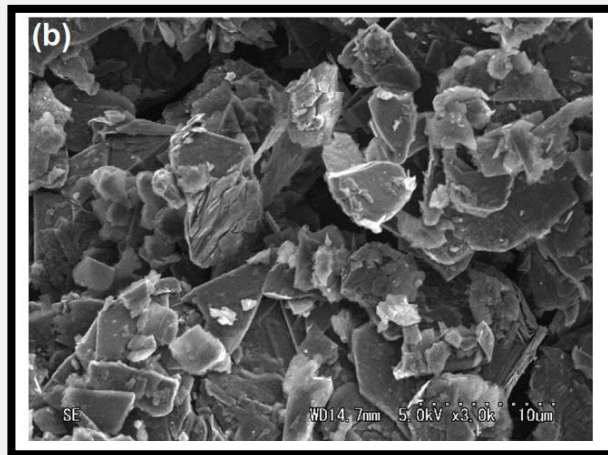

Graphite Powder

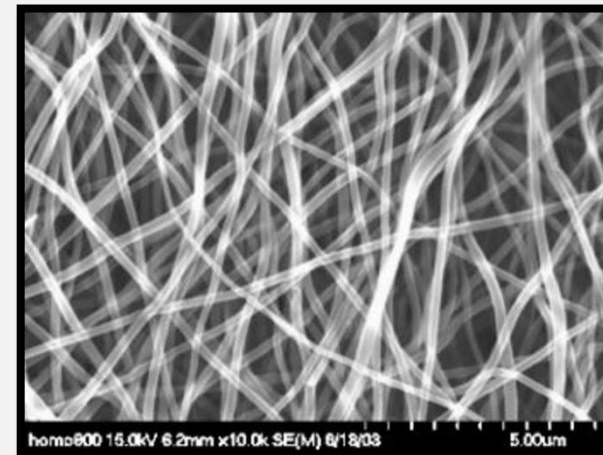

Carbon Nano Tube

# Materials of SSC

- Improvement of hybrid functional fillers to sensing properties of SSC.

<b>Hybrid Fillers</b>	<b>Improved Parameters</b>	<b>Compared Fillers</b>
Carbon fiber and carbon nanotube	Sensing reliability and sensitivity	Carbon fiber alone
Magnetic fly ash and steel slag	Sensing sensitivity	Magnetic fly ash or steel slag alone
Carbon fiber and carbon black	Sensing reproducibility and linearity	Carbon fiber alone
Carbon fiber and carbon nanotube	Sensing reproducibility and stability	Carbon fiber alone
Carbon nanotube and carbon black	Sensing sensitivity	Carbon nanotube alone
Carbon fiber and graphite powder	Stability of conductivity and sensing sensitivity	Carbon fiber alone

# Materials of SSC

## III. Dispersion Materials :

- It use for filler dispersion in concrete matrix and to improve homogeneity of concrete matrix.
- Benefits are obtaining reproducible and stable sensing and mechanical properties, achieving full realization of improvement effect of fillers & decreasing consumption of mechanical mixing energy.
- Two types of materials: 1. Surfactant  
2. Mineral Admixtures

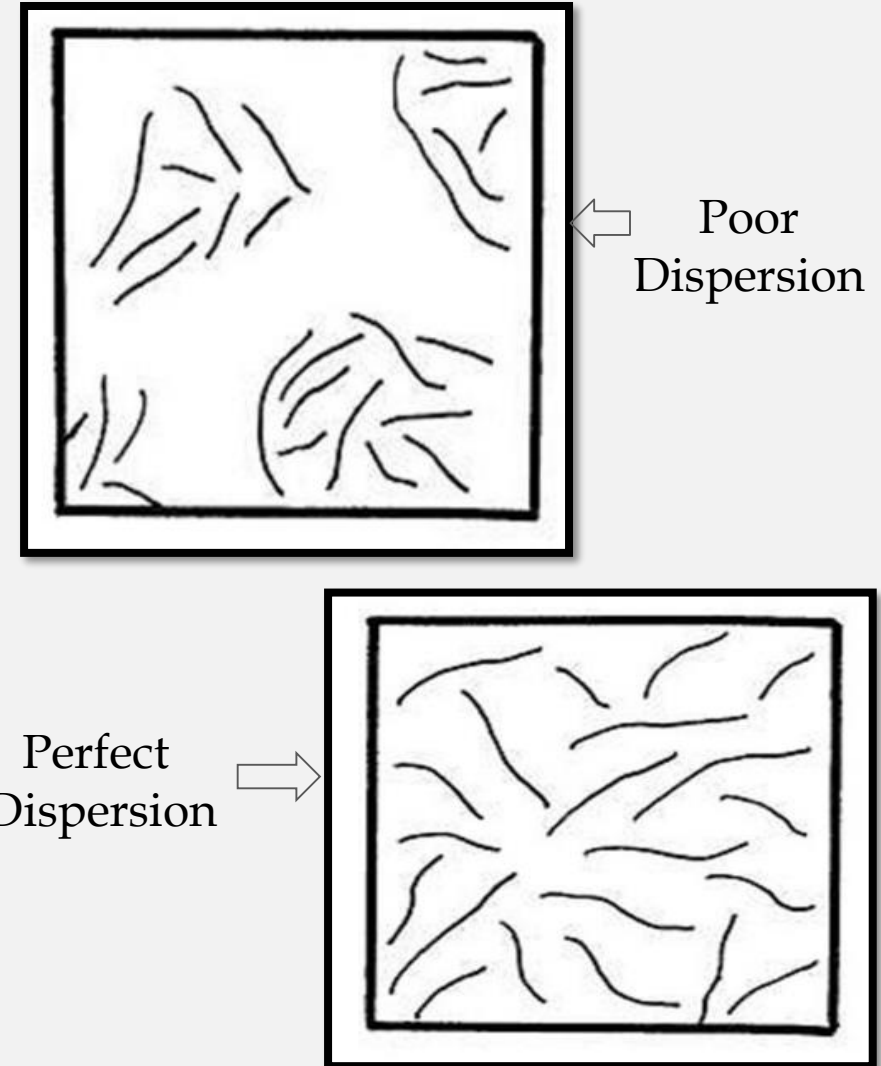



# Fabrication of SSC

- Effective fabrication technology needs to be adopted for incorporating each component into the composite, to obtain the composite with stable and reproducible properties.
- Fabrication includes **three steps** : mixing/ dispersing, concrete placing(molding)and curing.

## 1. Mixing/dispersing Process :

- There are three levels of dispersing in SSC
  1. Dispersing of function filler in binder.
  2. Dispersing of binder with function filler among fine aggregate.
  3. Dispersing of fine aggregate with binder and filler among coarse aggregate.

# Processing of self-sensing concrete

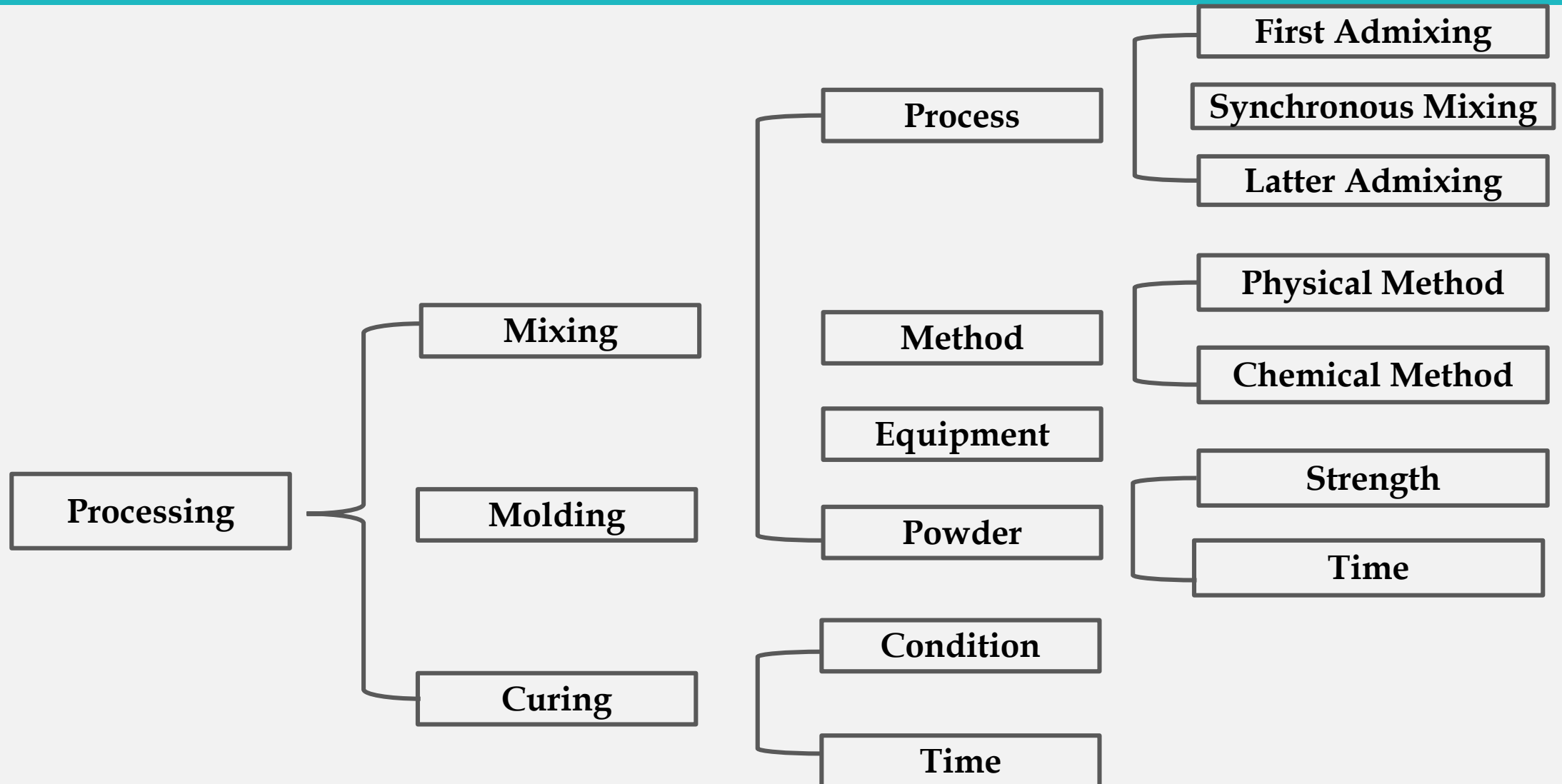

# Mixing Dispersing Processes for SSC

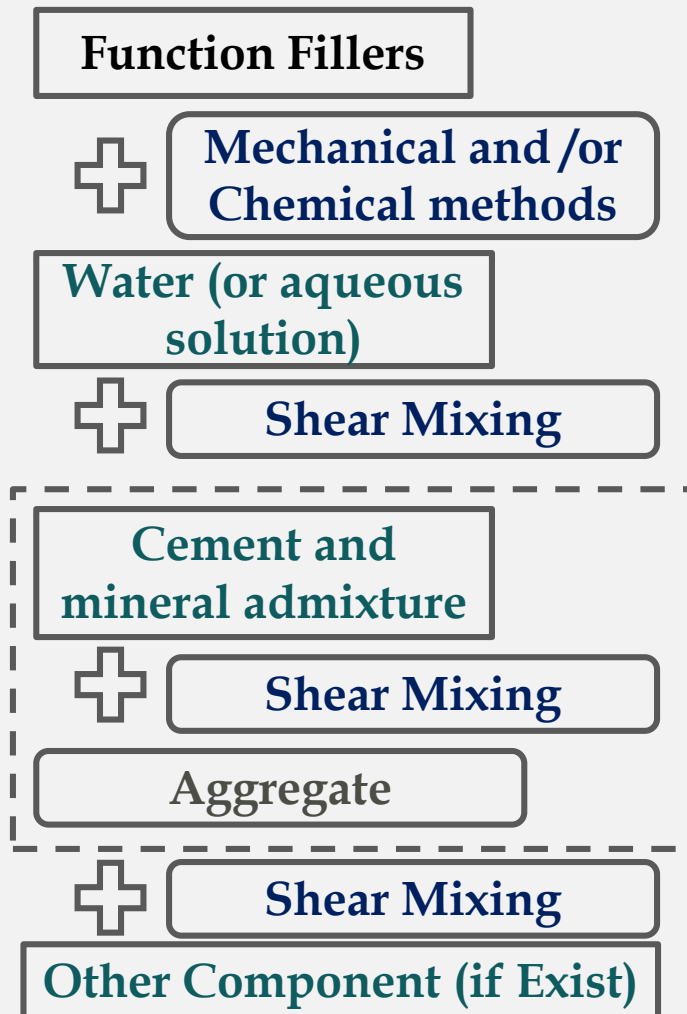

(a) First Admixing Method

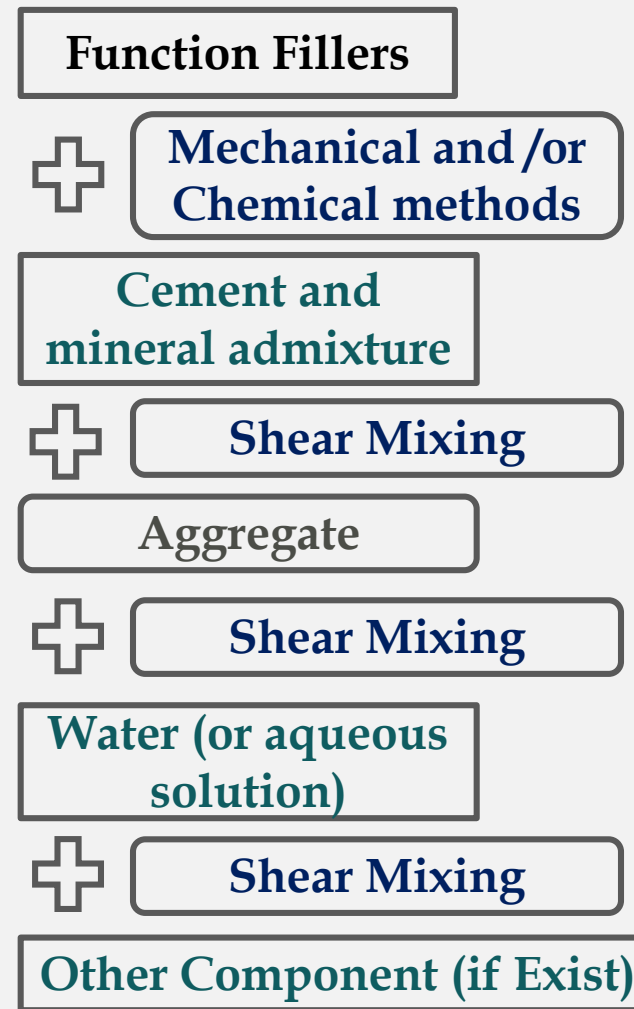

(b) Synchronous Admixing Method

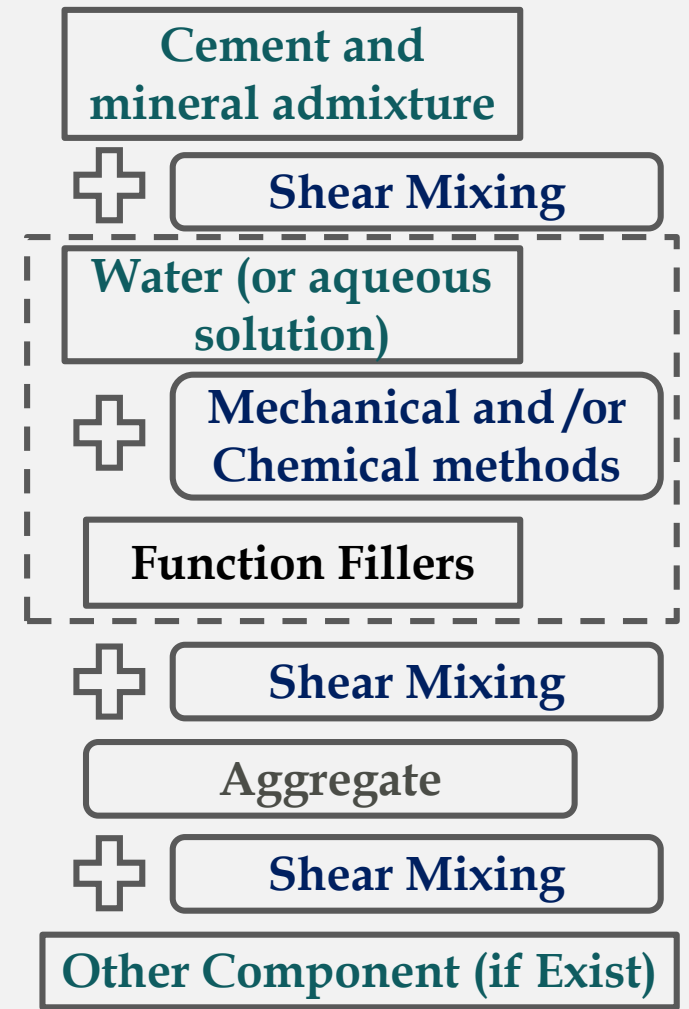

(c) Latter Admixing Method

# Fabrication of the electrodes for SSC

## ➤ Suitable Mixing/Dispersing processes for different functional fillers

Mixing / Dispersing Technology	Suitable Functional Fillers
First Admixing Method	CF, CNT, CNF, CB, Nano TiO <sub>2</sub> , Nano Fe <sub>2</sub> O <sub>3</sub>
Synchronous Admixing Method	CF, SF, SS, MFA, GP
Latter Admixing Method	CB, SF, NP, GP, PVAf
<b>Hybrid Method</b>	
Synchronous Admixing + Latter Admixing	CB + PVAf
First Admixing + Synchronous Admixing	CF + CB, CF + CNT
Synchronous Admixing + Latter Admixing	GP + CF

# Fabrication of SSC

## 2. Concrete placing :

- It is needed to shape the mixture and also determines the compaction of composite which is affecting the mechanical and sensing performances of composite.

## 3. Curing :

- It is effect on the hydration product and structures inside the SSC.
- In addition, the composite would present different mechanical properties, interface bonding between functional fillers and matrix , and water content under different curing regimes.

# Measurement of Sensing Signal of SSC

- The sensing property of the SSC stems the change of conductive network inside composite.

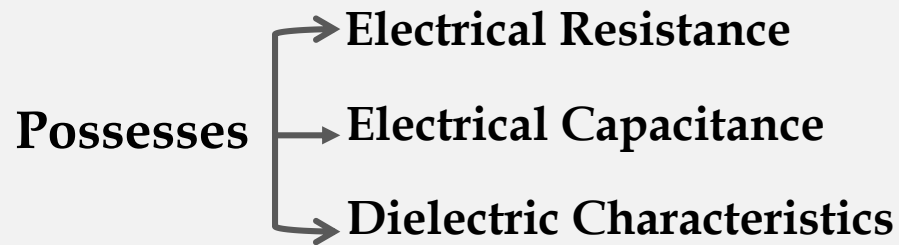

- Parameters measure in Sensing Signal

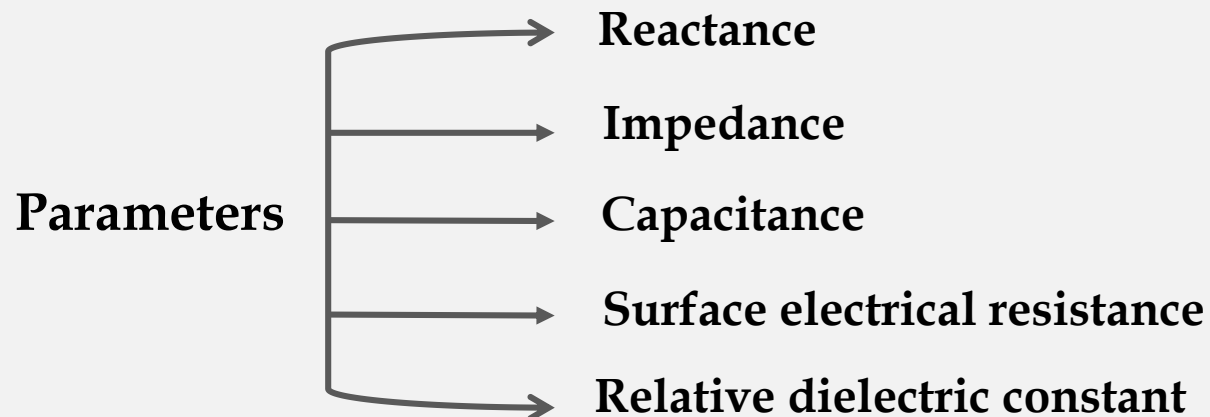

# Fabrication of the electrodes for SSC

## 1. Electrode Fabrication Method:

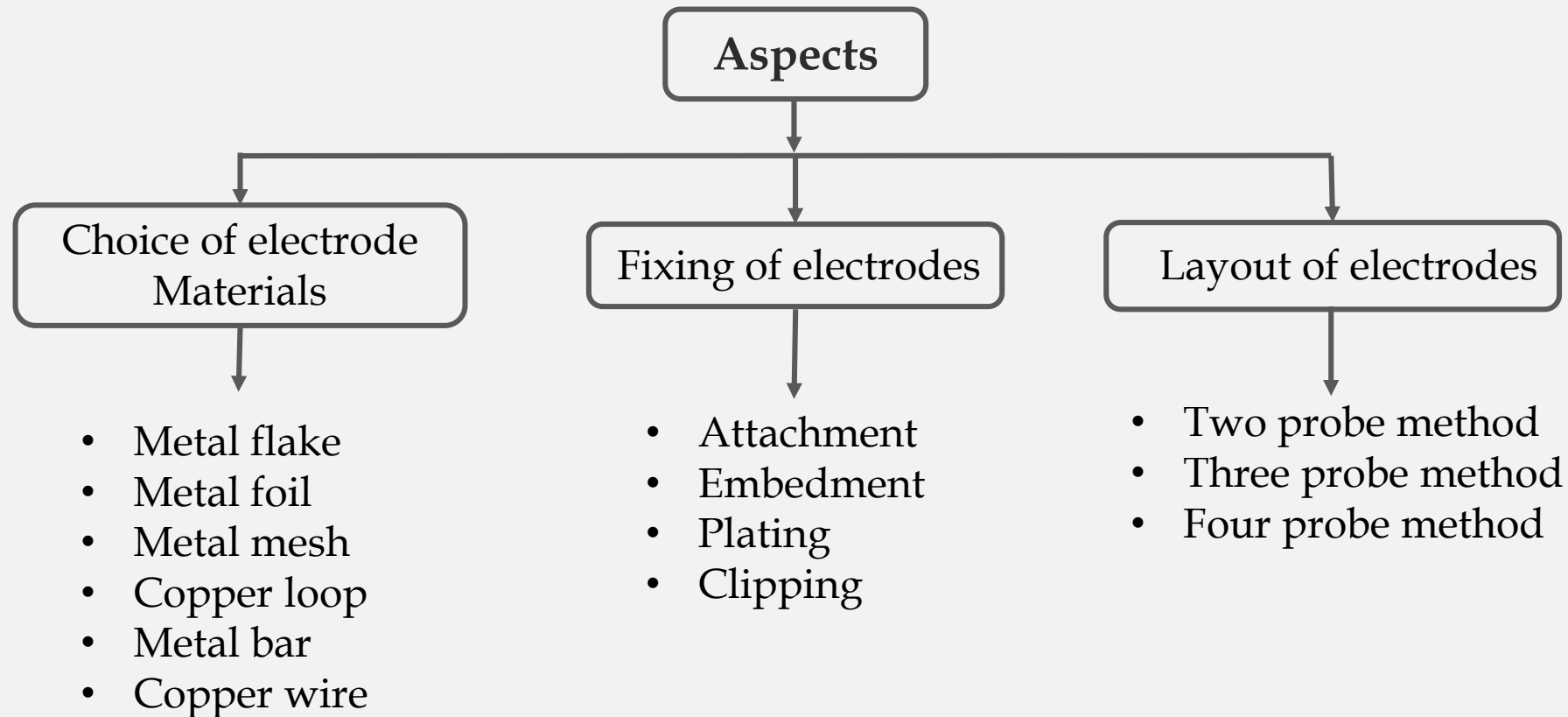

# Measurement of Sensing Signal of SSC

## 2. Measurement method of electrical resistance :

- The layout of electrodes, the electrical resistance measurement method of SSC include the **two-probe method**, **three probe method** and **four probe method**.

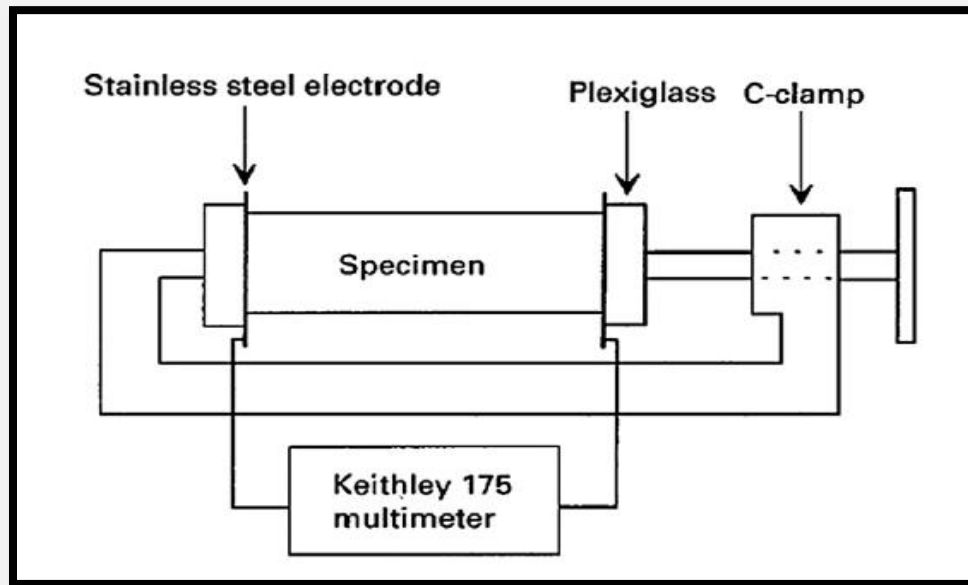

(a) Clipping fixing style of Two probe Methods

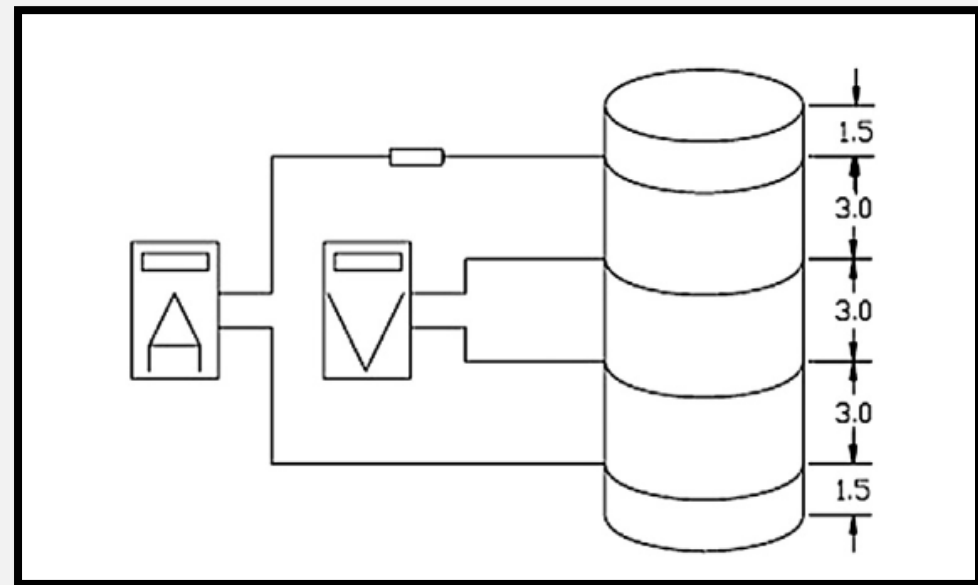

(b) Attachment fixing style of Four probe Methods



# Measurement of Sensing Signal of SSC

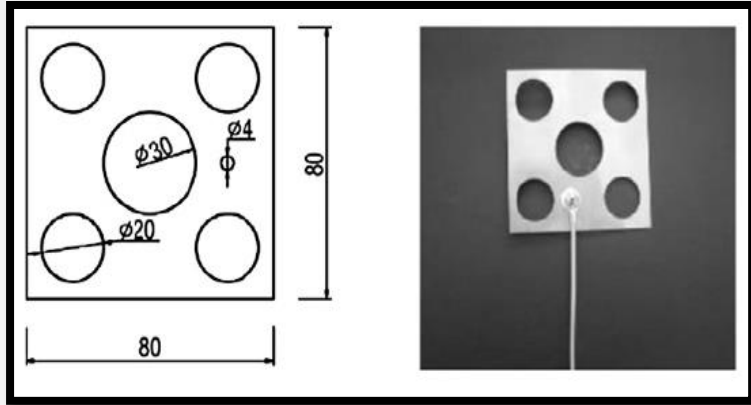

(a) Metal flake with hole as electrode

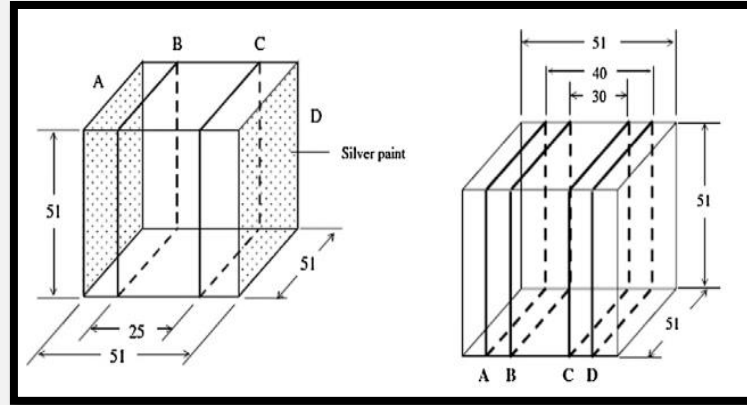

(b) Silver paint in conjunction with copper wire as electrode

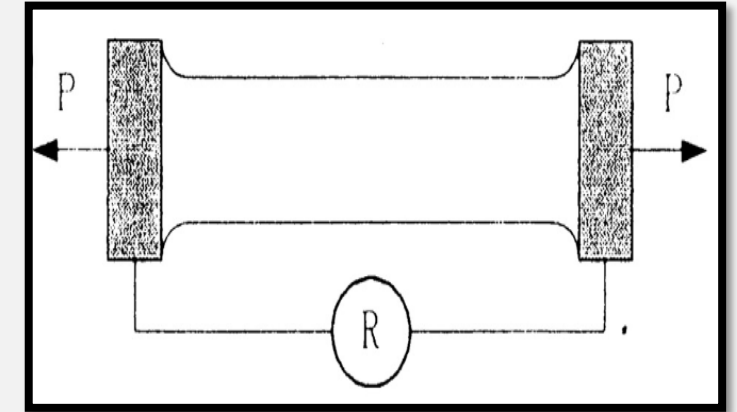

(c) Silver paint as electrode

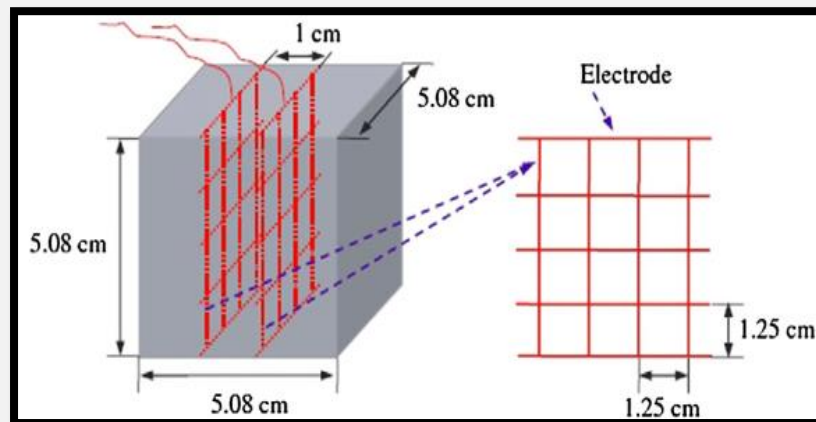

(d) Stainless steel mesh as electrode

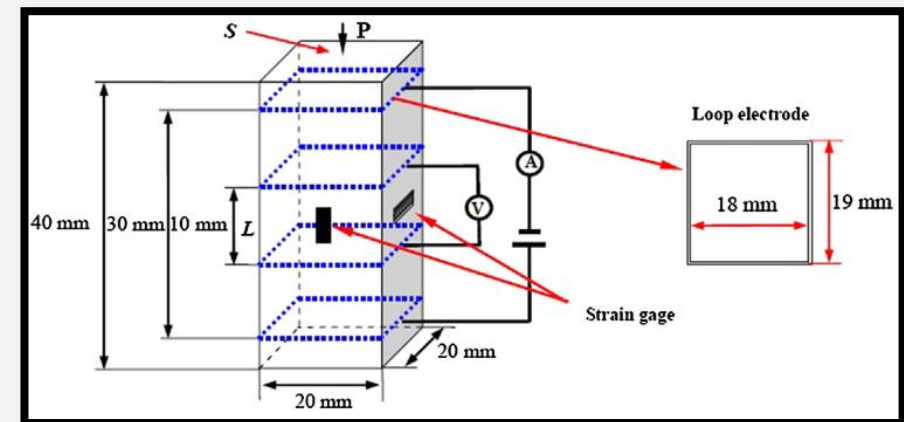

(e) Copper loop as electrode

# Fabrication of the electrodes for SSC

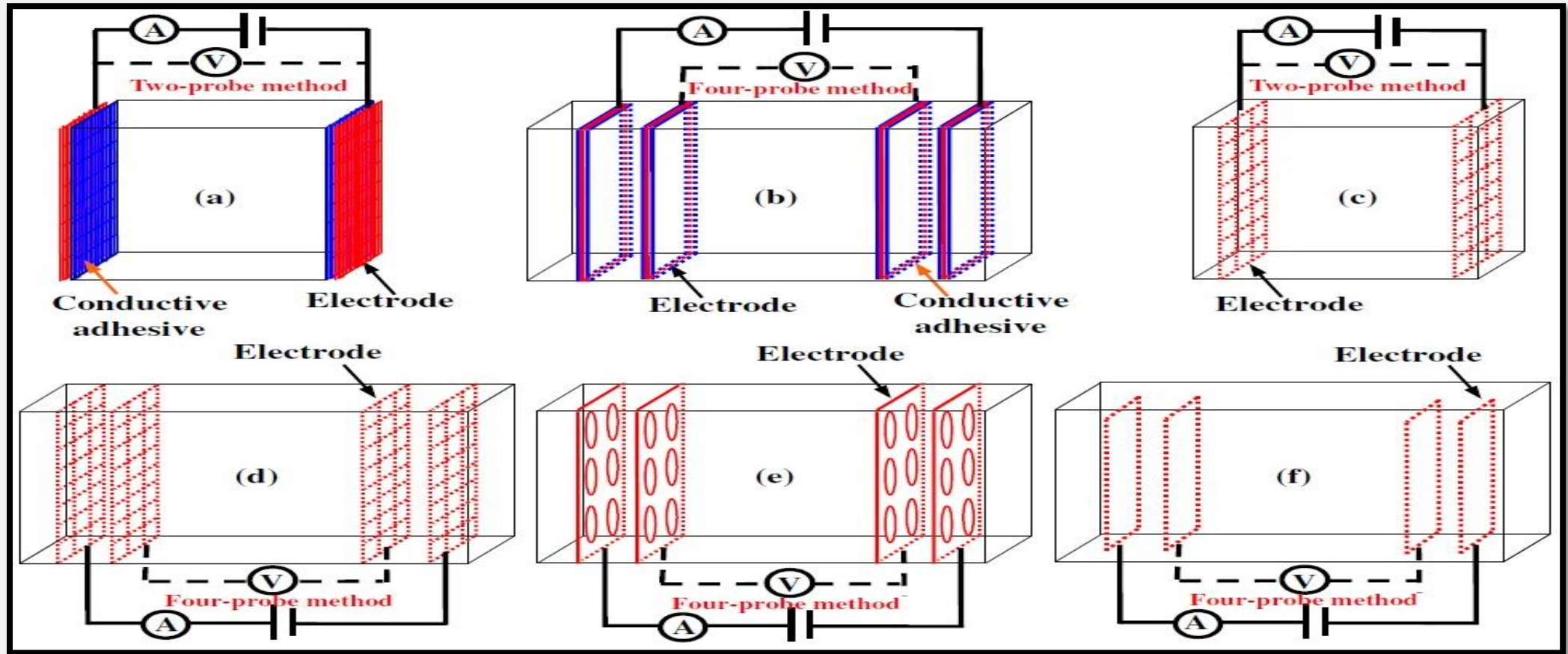

Commonly used fixing style and layout of electrodes in SSC

# Measurement of Sensing Signal of SSC

## 3. Acquisition & processing of sensing signal

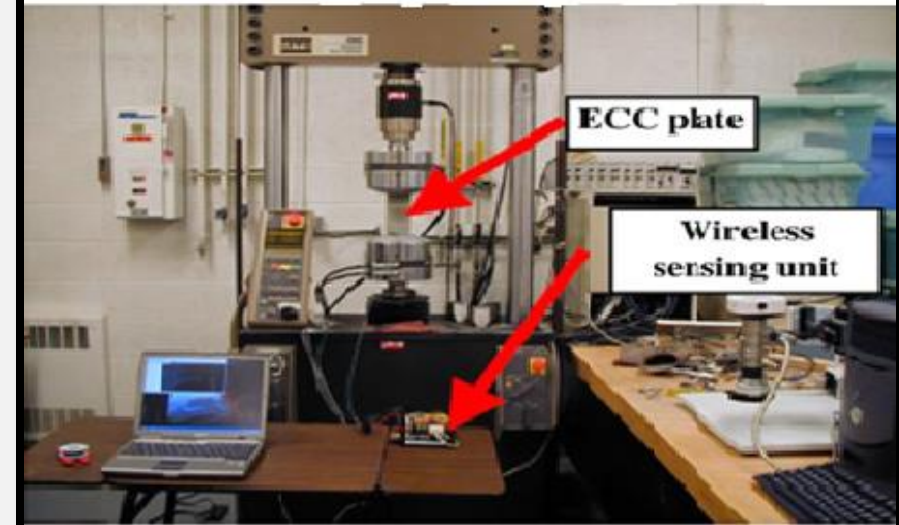
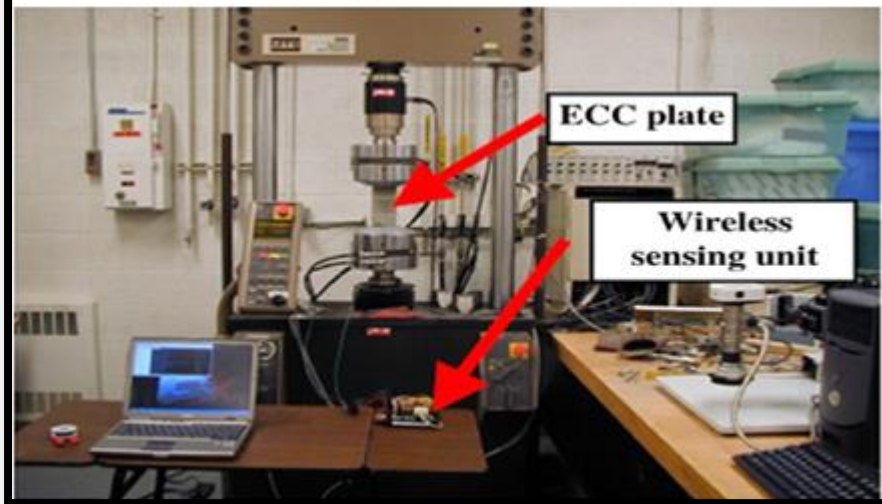
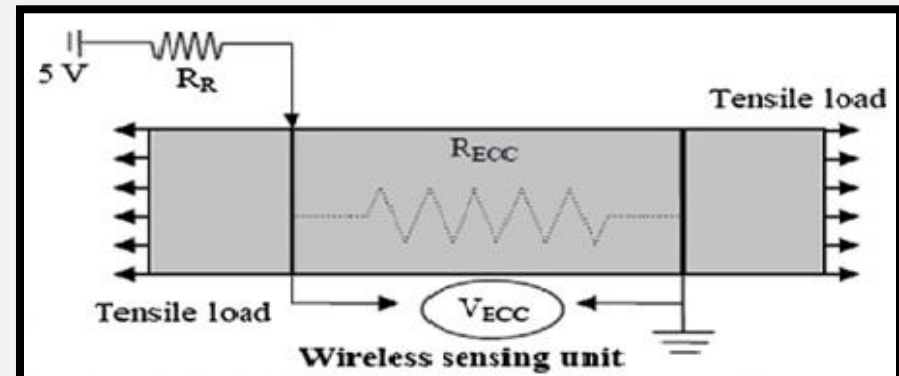
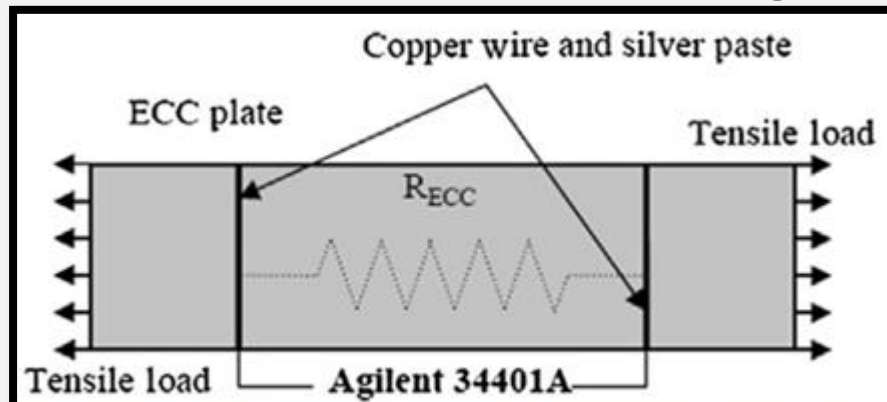

Experimental setup

# Sensing Mechanism of SSC

- Mechanism of electrical conduction and sensing properties of self-sensing concrete from four aspects

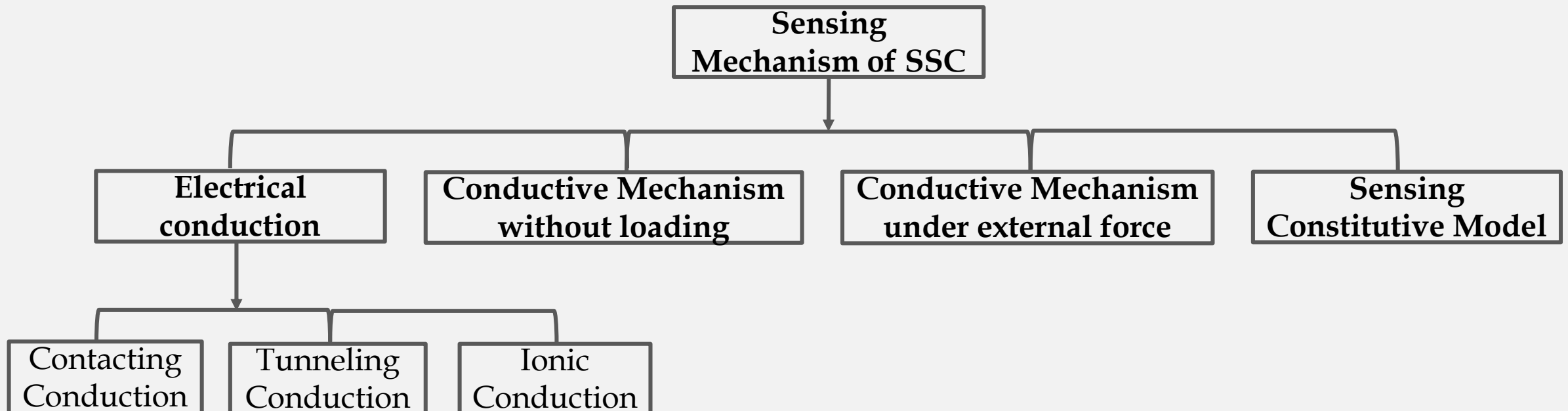

# Sensing Mechanism of SSC

## ➤ Conductive Mechanism without loading :

- The conductive characteristics of SSC are closely related to concentration of functional fillers. And it can be represent by conductive characteristic curve.
- Based on filler concentration the curve can be classified into 3 zones :
  1. Zone A : Insulation Zone
  2. Zone B : Percolation Zone
  3. Zone C : Conductive Zone

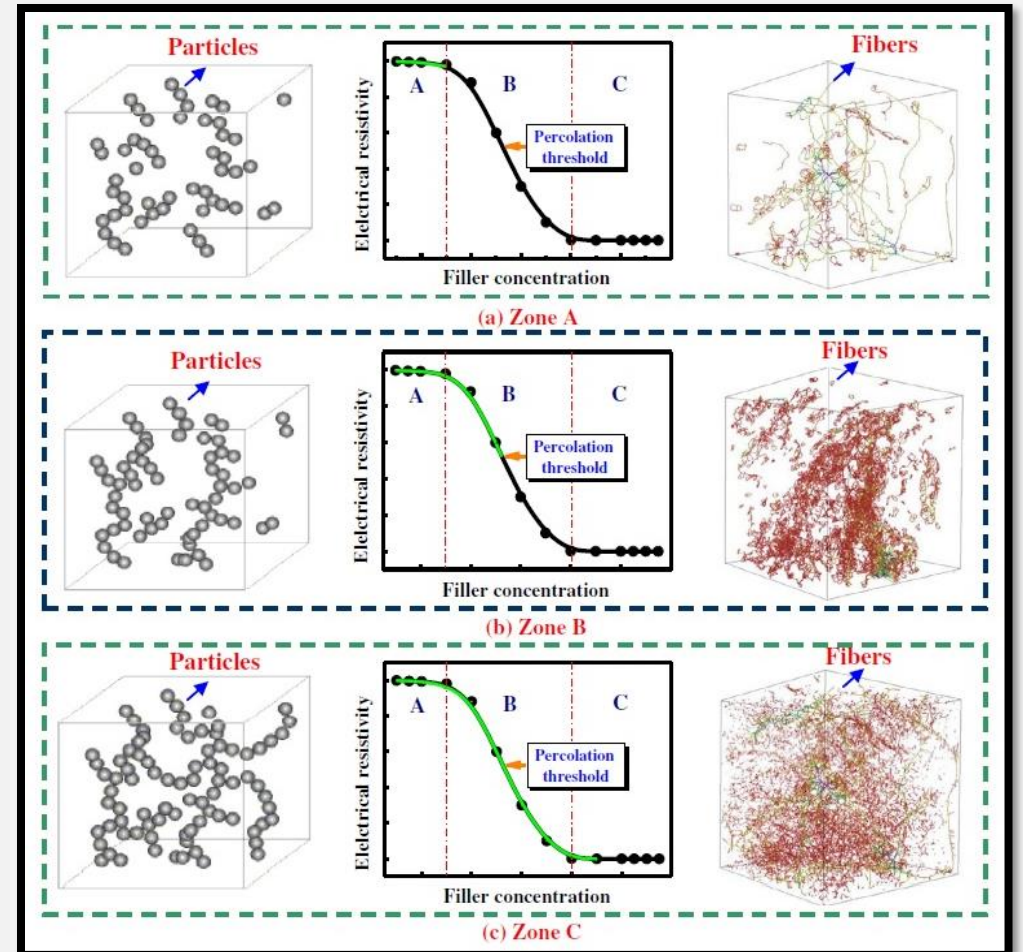

Change of the electrical resistivity along with filler concentration

# Sensing Mechanism of SSC

## ➤ **Conductive Mechanism under external force :**

- The electrical resistivity of SSC would change when concrete deforms under loading.
- Several factors may be contribute to the change in electrical resistivity :
  1. Change of intrinsic resistance of functional fillers
  2. Change of bonding between functional fillers and matrix
  3. Change of contact between functional filler
  4. Change of tunneling distance between functional filler
  5. Change in capacitance

# Sensing Mechanism of SSC

## ➤ Sensing Constitutive Model:

➤ The modeling principle and application goals of several sensing constitutive models for some typical SSC under different loading modes are summarized in table :

Type of SSC	Loading Mode	Modelling Principle	Goals of Model To Describe or Predict
With CF	Uniaxial compression	Percolation theory	Stress sensing behavior
	Uniaxial tension	Continuum mechanics	Load sensing behavior
	Bending		
With CF	Uniaxial tension	Change in contact electrical resistivity of fiber-matrix interface due to pull-out or pull-in of crack-bridging fiber.	Stress sensing behavior
	Uniaxial compression		
With NP	Uniaxial compression within elastic regime	Field emission effect	Stress sensing behavior
		Inter- particle separation change	Strain sensing behavior
With CF	Uniaxial compression	Ohmic continuum conduction	Strain sensing behavior
		Tunneling conduction	
With CB	Uniaxial compression	Tunneling effect	Strain sensing behavior

# Structural Application of SSC

- Owing to the capability to reflecting its inside stress, strain, crack and damage, SSC has potential application in fields Structural Health Monitoring , Traffic Detection. Also use for military/border security, corrosion monitoring of rebar, structural vibration control etc.

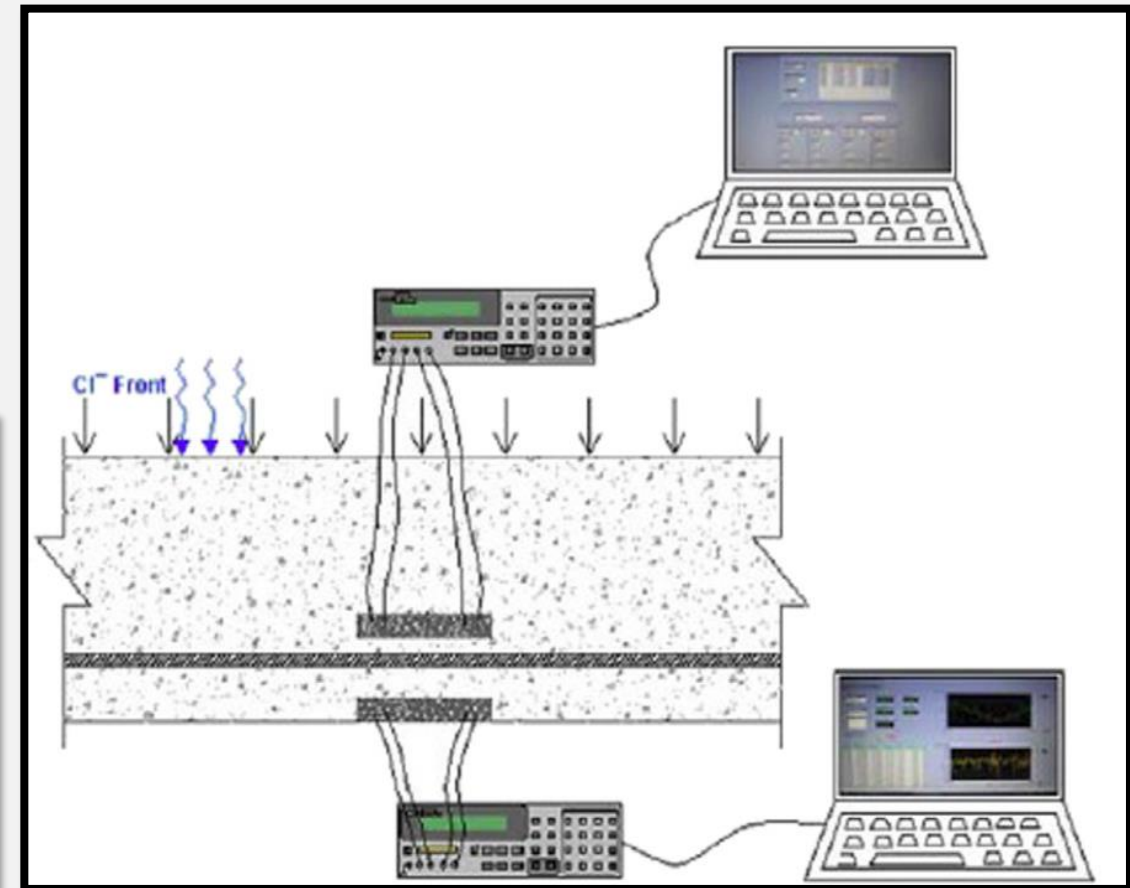
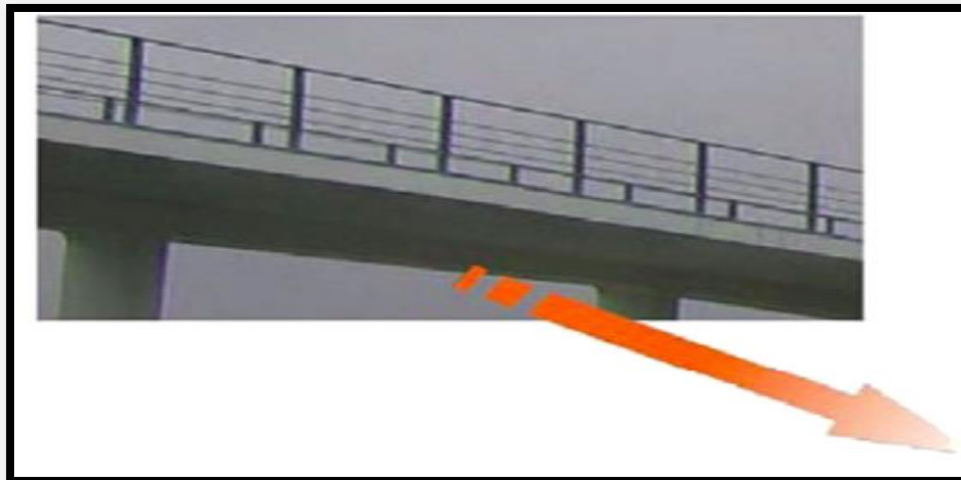

Structural health monitoring system of bridge based on SSC



# Structural Application of SSC

## 1. Structural Health Monitoring

- self-sensing concrete structure for structural health monitoring can be used
  - In Bulk Form
  - In Coating Form
  - In Sandwich Form
  - In Embedded Form
  - In Bonded Form

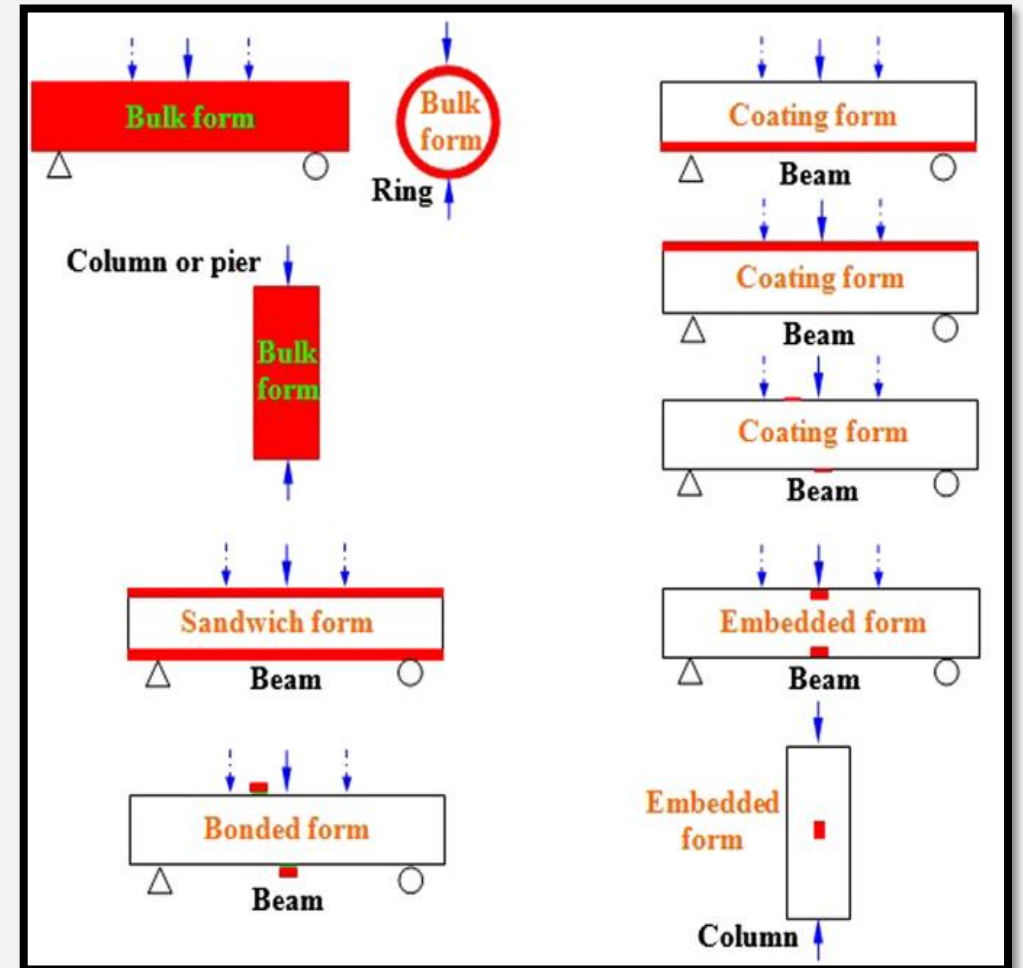

Typical application forms of self-sensing concrete for structural health monitoring

# Structural Application of SSC

## 2) Traffic Detection :

➤ It can be detect a lot of important traffic data i.e.,

Traffic flow rate

vehicular speed

traffic density

weighing in motion

vehicle type

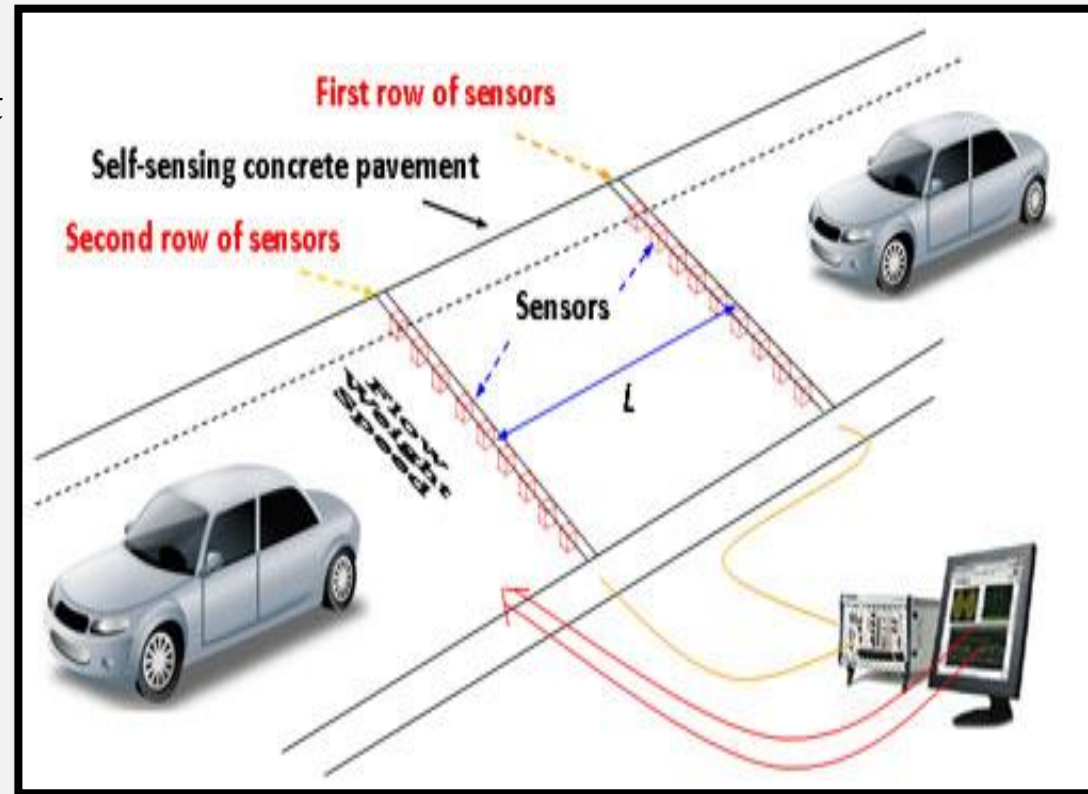

Schematic diagram of SSC pavement structure for vehicle detection

# Benefits and Limitations

## **Benefits :**

- High sensitivity
- Good mechanical property
- Natural compatibility
- Identical lifespan with concrete
- Easy installation & maintenance
- Improve serviceability, safety, reliability & durability
- Help in sensing and health monitoring abilities

# Benefits and Limitations

---

## **Limitations :**

- Cost of fiber is high
- Adverse effect on environment
- Increase noise pollution
- Used only for uni-axial loading



*Thank you*